

# Washdown Delta Robot R6Y3 Series

## Delta Robot

# MAINTENANCE MANUAL

**OMRON**



---

## Safety Instructions

<b>1. Safety Information</b>	<b>S-1</b>
<b>2. Signal words used in this manual</b>	<b>S-2</b>
<b>3. Warning labels</b>	<b>S-3</b>
3.1 Warning labels	S-3
3.1.1 Contents of warning label messages	S-3
3.1.2 Supplied warning label	S-4
3.2 Warning symbols	S-4
<b>4. Major precautions for each stage of use</b>	<b>S-5</b>
4.1 Precautions for using robots	S-5
4.2 Design	S-5
4.3 Moving and installation	S-6
4.4 Safety measures	S-8
4.4.1 Safety measures	S-8
4.4.2 Installing a safety enclosure	S-9
4.5 Operation	S-10
4.5.1 Trial operation	S-10
4.5.2 Automatic operation	S-10
4.5.3 Precautions during operation	S-10
4.6 Inspection and maintenance	S-11
4.6.1 Before inspection and maintenance work	S-11
4.6.2 Precautions during service work	S-12
4.7 Disposal	S-12
<b>5. Emergency action when a person is caught by robot</b>	<b>S-13</b>
<b>6. Using the robot safely</b>	<b>S-14</b>
6.1 Robot protective functions	S-14
6.2 Residual risk	S-14
6.3 Special training for industrial robot operation	S-14

---

## Warranty

---

## Chapter 1 Overview

1. Overview	1-1
-------------	-----

---

## Chapter 2 Attaching, detaching, and replacing the cover

1. Attaching, detaching and replacing the cover	2-1
1.1 Detaching or attaching the $\alpha$ , $\beta$ , $\gamma$ -axes covers	2-1
1.1.1 $\alpha$ , $\beta$ , $\gamma$ -axis cover removal procedure	2-2
1.1.2 $\alpha$ , $\beta$ and $\gamma$ -axis cover attachment procedure	2-7
1.2 Detaching or attaching the $\theta$ -axis cover	2-13
1.2.1 $\theta$ -axis motor cover removal	2-14
1.2.2 $\theta$ -axis motor cover attachment	2-16

---

## Chapter 3 Periodic inspection

1. Overview	3-1
2. Daily inspection	3-2
3. Monthly inspection	3-3
4. Six-month inspection	3-4

---

## Chapter 4 Adjusting the origin

1. Adjusting the origin	4-1
1.1 Adjusting the $\alpha$ , $\beta$ and $\gamma$ -axis origin position	4-2
1.2 Adjusting the $\theta$ -axis origin position (4-axes specification only)	4-5

---

## Chapter 5 Shaft, moveable base and spring cover replacement

1. Shaft, moveable base and spring cover replacement procedure	5-1
1.1 Detaching the shafts, moveable base and spring cover	5-1
1.2 Attaching the shafts, moveable base and spring covers	5-4
1.2.1 R6Y30110S03067NJ5 (3-axes specification)	5-4
1.2.2 R6Y31110L03067NJ5, R6Y31110H03067NJ5 (4-axes specification)	5-6
2. Moveable base link ball replacement	5-9

---

## Chapter 6 Spring mechanism replacement

1. Spring mechanism replacement procedure	6-1
1.1 Spring mechanism removal	6-1
1.2 Spring mechanism attachment	6-2

---

## Chapter 7 Plastic bearing replacement

<b>1. Plastic bearing replacement procedure</b>	<b>7-1</b>
1.1 Removing the plastic bearing from the link ball sliding part	7-1
1.2 Attach the jig with threaded screw to the tapping hole on the end of the shaft	7-2
1.3 Spring mechanism plate plastic bearing removal	7-4
1.4 Spring mechanism plate plastic bearing attachment	7-4
<b>2. Plastic bearing inspection</b>	<b>7-5</b>

---

## Chapter 8 $\theta$ -axis seal, O-ring replacement

<b>1. <math>\theta</math>-axis seal, O-ring replacement procedure</b>	<b>8-1</b>
1.1 $\theta$ -axis seal, O-ring removal	8-1
1.2 $\theta$ -axis seal, O-ring attachment	8-3

---

## Chapter 9 Motor replacement

<b>1. <math>\alpha</math>, <math>\beta</math>, <math>\gamma</math>-axis motor replacement</b>	<b>9-1</b>
1.1 $\alpha$ , $\beta$ , $\gamma$ -axis motor replacement procedure	9-1
1.1.1 $\alpha$ , $\beta$ , $\gamma$ -axis motor removal	9-1
1.1.2 $\alpha$ , $\beta$ , $\gamma$ -axis motor attachment	9-3
<b>2. <math>\theta</math>-axis motor replacement</b>	<b>9-4</b>
2.1 $\theta$ -axis motor removal	9-4

---

## Chapter 10 Speed reduction gear, arm replacement

<b>1. Speed reduction gear replacement precautions</b>	<b>10-1</b>
<b>2. Speed reduction gear and arm replacement procedure</b>	<b>10-2</b>
2.1 $\alpha$ , $\beta$ , $\gamma$ -axis arm replacement	10-2
2.1.1 Work required after replacing arm link balls	10-3
2.2 $\alpha$ , $\beta$ , $\gamma$ -axis speed reduction gear replacement	10-4
2.3 $\theta$ -axis speed reduction gear replacement	10-7

---

## Chapter 11 Maintenance parts

<b>1. Consumable parts</b>	<b>11-1</b>
<b>2. Basic specification</b>	<b>11-2</b>

---



# Safety Instructions

## Contents

<b>1. Safety Information</b>	<b>S-1</b>
<b>2. Signal words used in this manual</b>	<b>S-2</b>
<b>3. Warning labels</b>	<b>S-3</b>
<b>3.1 Warning labels</b>	<b>S-3</b>
3.1.1 Contents of warning label messages	S-3
3.1.2 Supplied warning label	S-4
<b>3.2 Warning symbols</b>	<b>S-4</b>
<b>4. Major precautions for each stage of use</b>	<b>S-5</b>
<b>4.1 Precautions for using robots</b>	<b>S-5</b>
<b>4.2 Design</b>	<b>S-5</b>
<b>4.3 Moving and installation</b>	<b>S-6</b>
<b>4.4 Safety measures</b>	<b>S-8</b>
4.4.1 Safety measures	S-8
4.4.2 Installing a safety enclosure	S-9
<b>4.5 Operation</b>	<b>S-10</b>
4.5.1 Trial operation	S-10
4.5.2 Automatic operation	S-10
4.5.3 Precautions during operation	S-10
<b>4.6 Inspection and maintenance</b>	<b>S-11</b>
4.6.1 Before inspection and maintenance work	S-11
4.6.2 Precautions during service work	S-12
<b>4.7 Disposal</b>	<b>S-12</b>
<b>5. Emergency action when a person is caught by robot</b>	<b>S-13</b>
<b>6. Using the robot safely</b>	<b>S-14</b>
<b>6.1 Robot protective functions</b>	<b>S-14</b>
<b>6.2 Residual risk</b>	<b>S-14</b>
<b>6.3 Special training for industrial robot operation</b>	<b>S-14</b>





# 1. Safety Information

Industrial robots are highly programmable, mechanical devices that provide a large degree of freedom when performing various manipulative tasks. To operate the robot in safer and correct manner, strictly observe the safety instructions and precautions stated in this "Safety Instructions" guide. Failure to take necessary safety measures or incorrect handling may result in trouble or damage to the robot, and also may cause personal injury (to installation personnel, robot operator or service personnel) including fatal accidents.

The safety instructions and precautions described in the "Safety Instructions" cover only the robot (mechanical sections). For details about operation of the controller and safety precautions associated with the controller operation, refer to the Controller Manual.

Before using this product, read this manual and related manuals and take safety precautions to ensure correct handling. The precautions listed in this manual relate to this product. To ensure the safety of the user's final system that includes robots, the user must take appropriate safety considerations.

To use robots safely and correctly, be sure to strictly observe the safety rules and instructions.

- For specific safety information and standards, refer to the applicable local regulations and comply with the instructions.
- Warning labels attached to the robots are written in English, Japanese, Chinese and Korean. This manual is available in English or Japanese (or some parts in Chinese). Unless the robot operators or service personnel understand these languages, do not permit them to handle the robot.
- Cautions regarding the official language of EU countries.

For equipment that will be installed in EU countries, the language used for the manuals, warning labels, operation screen characters, and CE declarations is English only.

Warning labels only have pictograms or else include warning messages in English. In the latter case, messages in Japanese or other languages might be added.

It is not possible to list all safety items in detail within the limited space of this manual. So please note that it is essential that the user have a full knowledge of safety and also make correct judgments on safety procedures.

## 2. Signal words used in this manual

This manual uses the following safety alert symbols and signal words to provide safety instructions that must be observed and to describe handling precautions, prohibited actions, and compulsory actions. Make sure you understand the meaning of each symbol and signal word and then read this manual.



### DANGER

THIS INDICATES AN IMMEDIATELY HAZARDOUS SITUATION WHICH, IF NOT AVOIDED, WILL RESULT IN DEATH OR SERIOUS INJURY.



### WARNING

THIS INDICATES A POTENTIALLY HAZARDOUS SITUATION WHICH, IF NOT AVOIDED, COULD RESULT IN DEATH OR SERIOUS INJURY.



### CAUTION

This indicates a potentially hazardous situation which, if not avoided, could result in minor or moderate injury, or damage to the equipment.



### NOTE

Explains the key point in the operation in a simple and clear manner.

## 3. Warning labels

Warning labels are attached to the robot body. To ensure correct use, read the warning labels and comply with the instructions.

### 3.1 Warning labels



#### WARNING

IF WARNING LABELS ARE REMOVED OR DIFFICULT TO SEE, THEN THE NECESSARY PRECAUTIONS MAY NOT BE TAKEN, RESULTING IN AN ACCIDENT.

- DO NOT REMOVE, ALTER OR STAIN THE WARNING LABELS ON THE ROBOT BODY.
- DO NOT ALLOW WARNING LABELS TO BE HIDDEN BY DEVICES INSTALLED ON THE ROBOT BY THE USER.
- PROVIDE PROPER LIGHTING SO THAT THE SYMBOLS AND INSTRUCTIONS ON THE WARNING LABELS CAN BE CLEARLY SEEN FROM OUTSIDE THE SAFETY ENCLOSURE.

#### 3.1.1 Contents of warning label messages

Word messages on the danger, warning and caution labels are concise and brief instructions. For more specific instructions, read and follow the "Instructions on this label" described on the right of each label shown below.

##### 1. Warning label 1



#### DANGER

SERIOUS INJURY MAY RESULT FROM CONTACT WITH A MOVING ROBOT.

- KEEP OUTSIDE OF THE ROBOT SAFETY ENCLOSURE DURING OPERATION.
- PRESS THE EMERGENCY STOP BUTTON BEFORE ENTERING THE SAFETY ENCLOSURE.

Instructions on this label	
	<ul style="list-style-type: none"> <li>• Always install a safety enclosure to keep all persons away from the robot movement range and prevent injury from contacting the moving part of the robot.</li> <li>• Install an interlock that triggers emergency stop when the door or gate of the safety enclosure is opened.</li> <li>• The safety enclosure should be designed so that no one can enter inside except from the door or gate equipped with an interlock device.</li> <li>• Warning label 1 that comes supplied with a robot should be affixed to an easy-to-see location on the door or gate of the safety enclosure.</li> </ul>
<b>Potential hazard to human body</b>	Serious injury may result from contact with a moving robot.
<b>To avoid hazard</b>	<ul style="list-style-type: none"> <li>• Keep outside of the robot safety enclosure during operation.</li> <li>• Press the emergency stop button before entering the safety enclosure.</li> </ul>

##### 2. Warning label 2



#### WARNING

MOVING PARTS CAN PINCH OR CRUSH HANDS.

KEEP HANDS AWAY FROM THE MOVABLE PARTS OF THE ROBOT.

Instructions on this label	
	<p>Use caution to prevent hands and fingers from being pinched or crushed by the movable parts of the robot when transporting or moving the robot or during teaching.</p>
<b>Potential hazard to human body</b>	Moving parts can pinch or crush hands.
<b>To avoid hazard</b>	Keep hands away from the movable parts of the robot.

### 3. Warning label 3



#### WARNING

IMPROPER INSTALLATION OR OPERATION MAY CAUSE SERIOUS INJURY.  
BEFORE INSTALLING OR OPERATING THE ROBOT, READ THE MANUAL AND INSTRUCTIONS ON THE WARNING LABELS AND UNDERSTAND THE CONTENTS.

Instructions on this label	
	<ul style="list-style-type: none"> <li>• Be sure to read the warning label and this manual carefully to make you completely understand the contents before attempting installation and operation of the robot.</li> <li>• Before starting the robot operation, even after you have read through this manual, read again the corresponding procedures and "Safety instructions" in this manual.</li> <li>• Never install, adjust, inspect or service the robot in any manner that does not comply with the instructions in this manual.</li> </ul>
Potential hazard to human body	Improper installation or operation may cause serious injury.
To avoid hazard	Before installing or operating the robot, read the manual and instructions on the warning labels and understand the contents.

#### 3.1.2 Supplied warning label



#### CAUTION

Attach the warning label that has been included in the robot at shipment to a legible location close to the robot, such as entrance of the safety enclosure.

## 3.2 Warning symbols

Warning symbols shown below are attached to the robot body to alert the operator to potential hazards. To use the OMRON robot safely and correctly always follow the instructions and cautions indicated by the symbols.

### 1. Electrical shock hazard symbol



#### WARNING

TOUCHING THE TERMINAL BLOCK OR CONNECTOR MAY CAUSE ELECTRICAL SHOCK, SO USE CAUTION.

Instructions by this symbol	
	<p>This indicates a high voltage is present. Touching the terminal block or connector may cause electrical shock.</p>

### 2. High temperature hazard symbol



#### WARNING

MOTORS, HEATSINKS, AND REGENERATIVE UNITS BECOME HOT, SO DO NOT TOUCH THEM.

Instructions by this symbol	
	<p>This indicates the area around this symbol may become very hot. Motors, heatsinks, and regenerative units become hot during and shortly after operation. To avoid burns be careful not to touch those sections.</p>

## 4. Major precautions for each stage of use

This section describes major precautions that must be observed when using robots. Be sure to carefully read and comply with all of these precautions even if there is no alert symbol shown.

### 4.1 Precautions for using robots

General precautions for using robots are described below.

#### 1. Applications where robots cannot be used

OMRON robots are designed as general-purpose industrial equipment and cannot be used for the applications listed below.



##### **DANGER**

ROBOTS ARE DESIGNED AS GENERAL-PURPOSE INDUSTRIAL EQUIPMENT AND CANNOT BE USED FOR THE FOLLOWING APPLICATIONS.

- IN MEDICAL EQUIPMENT SYSTEMS WHICH ARE CRITICAL TO HUMAN LIFE
- IN SYSTEMS THAT SIGNIFICANTLY AFFECT SOCIETY AND THE GENERAL PUBLIC
- IN EQUIPMENT INTENDED TO CARRY OR TRANSPORT PEOPLE
- IN ENVIRONMENTS WHICH ARE SUBJECT TO VIBRATION SUCH AS ONBOARD SHIPS AND VEHICLES.

#### 2. Qualification of operators/workers

Operators or persons who handle the robot such as for teaching, programming, movement check, inspection, adjustment, and repair must receive appropriate training and also have the skills needed to perform the job correctly and safely. They must read the manual carefully to understand its contents before attempting the robot operation or maintenance.

Tasks related to industrial robots (teaching, programming, movement check, inspection, adjustment, repair, etc.) must be performed by qualified persons who meet requirements established by local regulations and standards for industrial robots.



##### **WARNING**

- THE ROBOT MUST BE OPERATED ONLY BY PERSONS WHO HAVE RECEIVED SAFETY AND OPERATION TRAINING. OPERATION BY AN UNTRAINED PERSON IS EXTREMELY HAZARDOUS.
- ADJUSTMENT AND MAINTENANCE BY REMOVING A COVER REQUIRE SPECIALIZED TECHNICAL KNOWLEDGE AND SKILLS, AND MAY ALSO INVOLVE HAZARDS IF ATTEMPTED BY AN UNSKILLED PERSON. THESE TASKS MUST BE PERFORMED ONLY BY PERSONS WHO HAVE ENOUGH ABILITY AND QUALIFICATIONS IN ACCORDANCE WITH LOCAL LAWS AND REGULATIONS. FOR DETAILED INFORMATION, PLEASE CONTACT YOUR DISTRIBUTOR WHERE YOU PURCHASED THE PRODUCT.

### 4.2 Design

#### 1. Restricting the movement range



##### **WARNING**

SOFT LIMIT FUNCTION IS NOT A SAFETY-RELATED FUNCTION INTENDED TO PROTECT THE HUMAN BODY. ENSURE SAFETY BY INSTALLING A SAFETY ENCLOSURE AND SO ON.

#### 2. Provide safety measures for end effector (gripper, etc.)



##### **WARNING**

- END EFFECTORS MUST BE DESIGNED AND MANUFACTURED SO THAT THEY CAUSE NO HAZARDS (SUCH AS A LOOSE WORKPIECE OR LOAD) EVEN IF POWER (ELECTRICITY, AIR PRESSURE, ETC.) IS SHUT OFF OR POWER FLUCTUATIONS OCCUR.
- IF THE OBJECT GRIPPED BY THE END EFFECTOR MIGHT POSSIBLY FLY OFF OR DROP, THEN PROVIDE APPROPRIATE SAFETY PROTECTION TAKING INTO ACCOUNT THE OBJECT SIZE, WEIGHT, TEMPERATURE, AND CHEMICAL PROPERTIES.

#### 3. Provide adequate lighting

Provide enough lighting to ensure safety during work.

#### 4. Install an operation status light



##### WARNING

INSTALL A SIGNAL LIGHT (SIGNAL TOWER) AT AN EASY-TO-SEE POSITION SO THAT THE OPERATOR WILL BE AWARE OF THE ROBOT STOP STATUS (TEMPORARILY STOPPED, EMERGENCY STOP, ERROR STOP, ETC.).

### 4.3 Moving and installation

#### ■ Installation environment

##### 1. Do not use in strong magnetic fields



##### WARNING

DO NOT USE THE ROBOT NEAR EQUIPMENT OR IN LOCATIONS THAT GENERATE STRONG MAGNETIC FIELDS. THE ROBOT MAY BREAK DOWN OR MALFUNCTION IF USED IN SUCH LOCATIONS.

##### 2. Do not use in locations subject to possible electromagnetic interference, etc.



##### WARNING

DO NOT USE THE ROBOT IN LOCATIONS SUBJECT TO ELECTROMAGNETIC INTERFERENCE, ELECTROSTATIC DISCHARGE OR RADIO FREQUENCY INTERFERENCE. THE ROBOT MAY MALFUNCTION IF USED IN SUCH LOCATIONS CREATING HAZARDOUS SITUATIONS.

##### 3. Do not use in locations exposed to flammable gases



##### WARNING

- OMRON ROBOTS ARE NOT DESIGNED TO BE EXPLOSION-PROOF.
- DO NOT USE THE ROBOTS IN LOCATIONS EXPOSED TO EXPLOSIVE OR INFLAMMABLE GASES, DUST PARTICLES OR LIQUID. FAILURE TO FOLLOW THIS INSTRUCTION MAY CAUSE SERIOUS ACCIDENTS INVOLVING INJURY OR DEATH, OR LEAD TO FIRE.

#### ■ Moving

##### 1. Use caution to prevent pinching or crushing of hands or fingers



##### WARNING

KEEP YOUR HAND AWAY FROM THE ROBOT INSTALLATION SURFACE DURING MOVING. OTHERWISE, YOUR HAND IS ENTANGLED, CAUSING SERIOUS PERSONAL INJURY.

As instructed in Warning label 2, use caution to prevent hands or fingers from being pinched or crushed by movable parts when transporting or moving the robot. For details on warning labels, see "3. Warning labels" in "Safety instructions."

##### 2. Take safety measures when moving the robot

To ensure safety when moving the DELTA robot, use the eyebolts that come with the robot. Refer to the Robot Manual for details.

#### ■ Installation

##### 1. Protect electrical wiring and hydraulic/pneumatic hoses

Install a cover or similar item to protect the electrical wiring and hydraulic/pneumatic hoses from possible damage.

##### 2. Cautions on arm

In the installation work, do not hold the arm by your hand in case of an emergency.

## ■ Adjustment

### 1. Adjustment that requires removing a cover



#### WARNING

ADJUSTMENT BY REMOVING A COVER REQUIRE SPECIALIZED TECHNICAL KNOWLEDGE AND SKILLS, AND MAY ALSO INVOLVE HAZARDS IF ATEMPTED BY AN UNSKILLED PERSON. THESE TASKS MUST BE PERFORMED ONLY BY PERSONS WHO HAVE ENOUGH ABILITY AND QUALIFICATIONS IN ACORDANCE WITH LOCAL LAWS AND REGULATIONS. FOR DETAILED INFORMATION, PLEASE CONTACT YOUR DISTRIBUTOR WHERE YOU PURCHASED THE PRODUCT.

## ■ Wiring

### 1. Robot cable

After checking the specified combinations of the robot and controller, connect the robot and controller.

### 2. Wiring safety points



#### WARNING

ALWAYS SHUT OFF ALL PHASES OF THE POWER SUPPLY EXTERNALLY BEFORE STARTING INSTALLATION OR WIRING WORK. FAILURE TO DO THIS MAY CAUSE ELECTRICAL SHOCK OR PRODUCT DAMAGE.



#### CAUTION

- Do not apply excessive impacts or loads to the connectors when making cable connections. This might bend the connector pins or damage the internal PC board.
- When disconnecting the cable from the robot, do not hold the cable and pull it out by hand. Loosen the screws on the connector (if fastened with the screws), and then disconnect the cable. Trying to detach by pulling on the cable itself may damage the connector or cables, and poor cable contact will cause the controller or robot to malfunction.

### 3. Precautions for cable routing and installation



#### CAUTION

- Be sure to store the cables connected to the robot in the duct or clamp them securely in place. If the cables are not stored in a conduit or properly clamped, excessive play or movement or mistakenly pulling on the cable may damage the connector or cables, and poor cable contact will cause the controller or robot to malfunction.
- Do not modify the cables and do not place any heavy objects on them. Handle them carefully to avoid damage. Damaged cables may cause malfunction or electrical shock.
- If the cables connected to the controller may possibly become damaged, protect them with an appropriate cover, etc.
- Check that the control lines and communication cables are routed at a gap sufficiently away from main power supply circuits and power lines, etc. Bundling them together with power lines or close to power lines may cause faulty operation due to noise.

### 4. Protective measures against electrical shock



#### WARNING

ALWAYS GROUND THE ROBOT BODY EARTH TERMINAL. FAILURE TO DO SO MAY RESULT IN ELECTRIC SHOCK.

## 4.4 Safety measures

### 4.4.1 Safety measures

#### 1. Referring to warning labels and manual



##### WARNING

- BEFORE STARTING INSTALLATION OR OPERATION OF THE ROBOT, BE SURE TO READ THE WARNING LABELS AND THIS MANUAL, AND COMPLY WITH THE INSTRUCTIONS.
- NEVER ATTEMPT ANY REPAIR, PARTS REPLACEMENT AND MODIFICATION UNLESS DESCRIBED IN THIS MANUAL. THESE TASKS REQUIRE SPECIALIZED TECHNICAL KNOWLEDGE AND SKILLS AND MAY ALSO INVOLVE HAZARDS. PLEASE CONTACT YOUR DISTRIBUTOR FOR ADVICE.



##### NOTE

For details on warning labels, see "3. Warning labels" in "Safety instructions."

#### 2. Draw up "work instructions" and make the operators/workers understand them



##### WARNING

DECIDE ON "WORK INSTRUCTIONS" IN CASES WHERE PERSONNEL MUST WORK WITHIN THE ROBOT SAFETY ENCLOSURE TO PERFORM STARTUP OR MAINTENANCE WORK. MAKE SURE THE WORKERS COMPLETELY UNDERSTAND THESE "WORK INSTRUCTIONS".

Decide on "work instructions" for the following items in cases where personnel must work within the robot safety enclosure to perform teaching, maintenance or inspection tasks. Make sure the workers completely understand these "work instructions".

1. Robot operating procedures needed for tasks such as startup procedures and handling switches
2. Robot speeds used during tasks such as teaching
3. Methods for workers to signal each other when two or more workers perform tasks
4. Steps that the worker should take when a problem or emergency occurs
5. Steps to take after the robot has come to a stop when the emergency stop device was triggered, including checks for cancelling the problem or error state and safety checks in order to restart the robot.
6. In cases other than above, the following actions should be taken as needed to prevent hazardous situations due to sudden or unexpected robot operation or faulty robot operation as listed below.
  - Place a display sign on the operator panel
  - Ensure the safety of workers performing tasks within the robot safety enclosure
  - Clearly specify position and posture during work
    - Specify a position and posture where worker can constantly check robot movements and immediately move to avoid trouble if an error/problem occurs
  - Take noise prevention measures
  - Use methods for signaling operators of related equipment
  - Use methods to decide that an error has occurred and identify the type of error

Implement the "work instructions" according to the type of robot, installation location, and type of work task.

When drawing up the "work instructions", make an effort to include opinions from the workers involved, equipment manufacturer technicians, and workplace safety consultants, etc.

#### 3. Take safety measures



##### DANGER

- NEVER ENTER THE ROBOT MOVEMENT RANGE WHILE THE ROBOT IS OPERATING OR THE MAIN POWER IS TURNED ON. FAILURE TO FOLLOW THIS WARNING MAY CAUSE SERIOUS ACCIDENTS INVOLVING INJURY OR DEATH. INSTALL A SAFETY ENCLOSURE OR A GATE INTERLOCK WITH AN AREA SENSOR TO KEEP ALL PERSONS AWAY FROM THE ROBOT MOVEMENT RANGE.
- WHEN IT IS NECESSARY TO OPERATE THE ROBOT WHILE YOU ARE WITHIN THE ROBOT MOVEMENT RANGE SUCH AS FOR TEACHING OR MAINTENANCE/INSPECTION TASKS, BE SURE TO INSTALL AN ENABLE DEVICE IN THE EXTERNAL SAFETY CIRCUIT SO THAT YOU CAN IMMEDIATELY STOP THE ROBOT OPERATION IN CASE OF AN ABNORMAL OR HAZARDOUS CONDITION. ADDITIONALLY, SET THE ROBOT MOVING SPEED SO THAT IT COMPLIES WITH THE ROBOT SAFETY STANDARDS.



**WARNING**

- DURING STARTUP OR MAINTENANCE TASKS, DISPLAY A SIGN STATING "WORK IN PROGRESS " ON THE OPERATION PANEL OR LOCK THE COVER OF THE OPERATION PANEL IN ORDER TO PREVENT ANYONE OTHER THAN THE PERSON FOR THAT TASK FROM MISTAKENLY OPERATING THE START OR SELECTOR SWITCH.
- ALWAYS CONNECT THE ROBOT AND ROBOT CONTROLLER IN THE CORRECT COMBINATION. USING THEM IN AN INCORRECT COMBINATION MAY CAUSE FIRE OR BREAKDOWN.

#### 4. Install brake release circuit

The DELTA robot is equipped with a brake release switch for the manual teaching or maintenance inspection. To use this brake release switch, it is also necessary to install a brake release circuit on the user side. For details, see "4.2 Wiring the brake release wire connector" in Chapter 2 of the Installation Manual.

**WARNING**

WHEN PERFORMING THE TEACHING OR MAINTENANCE INSPECTION MANUALLY, INSTALL THE BRAKE RELEASE CIRCUIT TO ENSURE THE SAFETY.

#### 5. Install system

When configuring an automated system using a robot, hazardous situations are more likely to occur from the automated system than the robot itself. So the system manufacturer should install the necessary safety measures required for the individual system. The system manufacturer should provide a proper manual for safe, correct operation and servicing of the system.

**WARNING**

TO CHECK THE ROBOT CONTROLLER OPERATING STATUS, REFER TO THE RELATED MANUALS. DESIGN AND INSTALL THE SYSTEM INCLUDING THE ROBOT CONTROLLER SO THAT IT WILL ALWAYS WORK SAFELY.

#### 6. Do not modify

**WARNING**

NEVER ATTEMPT TO MODIFY THE ROBOT. DO NOT OPEN ANY COVER. DOING SO MAY CAUSE ELECTRICAL SHOCK, BREAKDOWN, MALFUNCTION, INJURY, OR FIRE.

### 4.4.2 Installing a safety enclosure

Be sure to install a safety enclosure to keep anyone from entering within the movement range of the robot. The safety enclosure will prevent the operator and other persons from coming in contact with moving parts of the robot and suffering injury.

**DANGER**

- SERIOUS INJURY MAY RESULT FROM CONTACT WITH A MOVING ROBOT.
- KEEP OUTSIDE OF THE ROBOT SAFETY ENCLOSURE DURING OPERATION.
  - PRESS THE EMERGENCY STOP BUTTON BEFORE ENTERING THE SAFETY ENCLOSURE.

**WARNING**

- INSTALL AN INTERLOCK THAT TRIGGERS EMERGENCY STOP WHEN THE DOOR OR GATE OF THE SAFETY ENCLOSURE IS OPENED.
- THE SAFETY ENCLOSURE SHOULD BE DESIGNED SO THAT NO ONE CAN ENTER INSIDE EXCEPT FROM THE DOOR OR GATE EQUIPPED WITH AN INTERLOCK DEVICE.
- WARNING LABEL 1 (SEE "3. WARNING LABELS" IN "SAFETY INSTRUCTIONS") THAT COMES SUPPLIED WITH A ROBOT SHOULD BE AFFIXED TO AN EASY-TO-SEE LOCATION ON THE DOOR OR GATE OF THE SAFETY ENCLOSURE.

## 4.5 Operation

When operating a robot, ignoring safety measures and checks may lead to serious accidents. Always take the following safety measures and checks to ensure safe operation.



### DANGER

CHECK THE FOLLOWING POINTS BEFORE STARTING ROBOT OPERATION.

- NO ONE IS WITHIN THE ROBOT SAFETY ENCLOSURE.
- THE ROBOT AND PERIPHERAL EQUIPMENT ARE IN GOOD CONDITION.

### 4.5.1 Trial operation

Refer to the controller user's manual after carrying out robot installation, adjustments, inspection, maintenance, or repair.

### 4.5.2 Automatic operation

To perform the automatic operation, follow the instructions stated in the controller manual.

### 4.5.3 Precautions during operation

#### 1. When the robot is damaged or an abnormal condition occurs



### WARNING

- IF UNUSUAL ODORS, NOISE OR SMOKE OCCUR DURING OPERATION, IMMEDIATELY TURN OFF POWER TO PREVENT POSSIBLE ELECTRICAL SHOCK, FIRE OR BREAKDOWN. STOP USING THE ROBOT AND CONTACT YOUR DISTRIBUTOR.
- IF ANY OF THE FOLLOWING DAMAGE OR ABNORMAL CONDITIONS OCCURS THE ROBOT, THEN CONTINUING TO OPERATE THE ROBOT IS DANGEROUS. IMMEDIATELY STOP USING THE ROBOT AND CONTACT YOUR DISTRIBUTOR.

Damage or abnormal condition	Type of danger
Damage to machine harness or robot cable	Electrical shock, robot malfunction
Damage to robot exterior	Damaged parts fly off during robot operation
Abnormal robot operation (position deviation, vibration, etc.)	Robot malfunction
$\alpha$ -axis, $\beta$ -axis or $\gamma$ -axis brake malfunction	Shaft or movable base falling or related part fly off

#### 2. High temperature hazard



### WARNING

- DO NOT TOUCH THE ROBOT DURING OPERATION. THE ROBOT BODY IS VERY HOT DURING OPERATION, SO BURNS MAY OCCUR IF YOU TOUCH THESE SECTIONS.
- THE MOTOR AND SPEED REDUCTION GEAR CASING ARE VERY HOT SHORTLY AFTER OPERATION, SO BURNS MAY OCCUR IF THESE ARE TOUCHED. BEFORE TOUCHING THOSE PARTS FOR INSPECTIONS OR SERVICING, TURN OFF THE CONTROLLER, WAIT FOR A WHILE AND CHECK THAT THEIR TEMPERATURE HAS COOLED.

#### 3. Use caution when releasing the $\alpha$ -axis, $\beta$ -axis or $\gamma$ -axis brake

To release the brake, it is necessary to install a brake release circuit on the user side.



### WARNING

- THE  $\alpha$ -AXIS,  $\beta$ -AXIS OR  $\gamma$ -AXIS WILL SLIDE DOWNWARD WHEN THE BRAKE IS RELEASED, CAUSING A HAZARDOUS SITUATION. TAKE ADEQUATE SAFETY MEASURES BY TAKING THE WEIGHT AND SHAPE INTO ACCOUNT.
- BEFORE RELEASING THE BRAKE AFTER PRESSING THE EMERGENCY STOP BUTTON, PLACE A SUPPORT UNDER THE  $\alpha$ -AXIS,  $\beta$ -AXIS OR  $\gamma$ -AXIS SO THAT IT WILL NOT SLIDE DOWN.
- WHEN PERFORMING TASKS (DIRECT TEACHING, ETC.) WITH THE BRAKE RELEASED, RELEASE THE BRAKE OF ONLY NECESSARY AXIS AND BE CAREFUL NOT TO LET YOUR BODY GET CAUGHT BETWEEN THE MOVABLE BASE AND THE INSTALLATION BASE.

#### 4. If the $\alpha$ -axis, $\beta$ -axis, $\gamma$ -axis or $\theta$ -axis operating angle is small



##### WARNING

IF THE  $\alpha$ -AXIS,  $\beta$ -AXIS,  $\gamma$ -AXIS OR  $\theta$ -AXIS ROTATION ANGLE IS SET SMALLER THAN 5 DEGREES, THEN IT WILL ALWAYS MOVE WITHIN THE SAME POSITION, IF THE ROTATION ANGLE OF THE  $\alpha$ -AXIS,  $\beta$ -AXIS,  $\gamma$ -AXIS OR  $\theta$ -AXIS IS SET AS SMALLER THAN 5 DEGREES, MOVEMENT WILL ALWAYS OCCUR AT THE SAME POSITION, MAKING IT DIFFICULT FOR A PROPER OIL FILM TO FORM ON THE SPEED REDUCTION GEAR, POSSIBLY SHORTENING ITS SERVICE LIFE. TO PREVENT THIS, ADD A RANGE OF MOTION SO THAT EACH AXIS MOVES THROUGH A RANGE OF 120 DEGREES OR MORE ABOUT 5 TIMES A DAY.

## 4.6 Inspection and maintenance

Always perform daily and periodic inspections and make a pre-operation check to ensure there are no problems with the robot and related equipment. If a problem or abnormality is found, then promptly repair it or take other measures as necessary.

Keep a record of periodic inspections or repairs and store this record for at least 3 years.

### 4.6.1 Before inspection and maintenance work

#### 1. Do not attempt any work or operation unless described in this manual.

Never attempt any work or operation unless described in this manual.



##### WARNING

NEVER ATTEMPT INSPECTION, MAINTENANCE, REPAIR, AND PART REPLACEMENT UNLESS DESCRIBED IN THIS MANUAL. THESE TASKS REQUIRE SPECIALIZED TECHNICAL KNOWLEDGE AND SKILLS AND MAY ALSO INVOLVE HAZARDS. PLEASE BE SURE TO CONTACT YOUR DISTRIBUTOR FOR ADVICE.

#### 2. Precautions during repair and parts replacement



##### WARNING

IF IT IS ABSOLUTELY REQUIRED TO REPAIR OR REPLACE ANY PART OF THE ROBOT, PLEASE BE SURE TO CONTACT YOUR DISTRIBUTOR AND FOLLOW THE INSTRUCTIONS THEY PROVIDE. INSPECTION AND MAINTENANCE OF THE ROBOT BY AN UNSKILLED OR UNTRAINED PERSON IS EXTREMELY HAZARDOUS.

Adjustment, maintenance and parts replacement require specialized technical knowledge and skills, and also may involve hazards. These tasks must be performed only by persons who have enough ability and qualifications required by local laws and regulations.



##### WARNING

ADJUSTMENT AND MAINTENANCE BY REMOVING A COVER REQUIRE SPECIALIZED TECHNICAL KNOWLEDGE AND SKILLS, AND MAY ALSO INVOLVE HAZARDS IF ATTEMPTED BY AN UNSKILLED PERSON. FOR DETAILED INFORMATION, PLEASE CONTACT YOUR DISTRIBUTOR WHERE YOU PURCHASED THE PRODUCT.

#### 3. Shut off all phases of power supply



##### WARNING

ALWAYS SHUT OFF ALL PHASES OF THE POWER SUPPLY EXTERNALLY BEFORE CLEANING THE ROBOT AND CONTROLLER OR SECURELY TIGHTENING THE TERMINAL SCREWS ETC. FAILURE TO DO THIS MAY CAUSE ELECTRICAL SHOCK OR PRODUCT DAMAGE OR MALFUNCTION.

#### 4. Allow a waiting time after power is shut off (Allow time for temperature and voltage to drop)



##### WARNING

THE MOTOR AND SPEED REDUCTION GEAR CASING ARE VERY HOT SHORTLY AFTER OPERATION, SO BURNS MAY OCCUR IF THEY ARE TOUCHED. BEFORE TOUCHING THOSE PARTS FOR INSPECTIONS OR SERVICING, TURN OFF THE CONTROLLER, WAIT FOR A WHILE AND CHECK THAT THE TEMPERATURE HAS COOLED.

## 4.6.2 Precautions during service work

---

### 1. Precautions when removing a motor



#### WARNING

THE  $\alpha$ -AXIS,  $\beta$ -AXIS OR  $\gamma$ -AXIS WILL SLIDE DOWNWARD WHEN THE MOTOR IS REMOVED, CAUSING A HAZARDOUS SITUATION .

- TURN OFF THE CONTROLLER AND PLACE A SUPPORT UNDER THE  $\alpha$ -AXIS,  $\beta$ -AXIS OR  $\gamma$ -AXIS BEFORE REMOVING THE MOTOR.
  - BE CAREFUL NOT TO LET YOUR BODY GET CAUGHT BETWEEN THE MOVABLE BASE AND THE INSTALLATION BASE.
- 

## 4.7 Disposal

---

When disposing of robots and related items, handle them carefully as industrial wastes. Use the correct disposal method in compliance with your local regulations, or entrust disposal to a licensed industrial waste disposal company.

### 1. Disposal of packing boxes and materials

When disposing of packing boxes and materials, use the correct disposal method in compliance with your local regulations. We do not collect and dispose of the used packing boxes and materials.

## 5. Emergency action when a person is caught by robot

If a person is caught in between the robot and mechanical section, such as installation base, use the brake release switch on the robot main unit to release the axis.

### Brake release switch

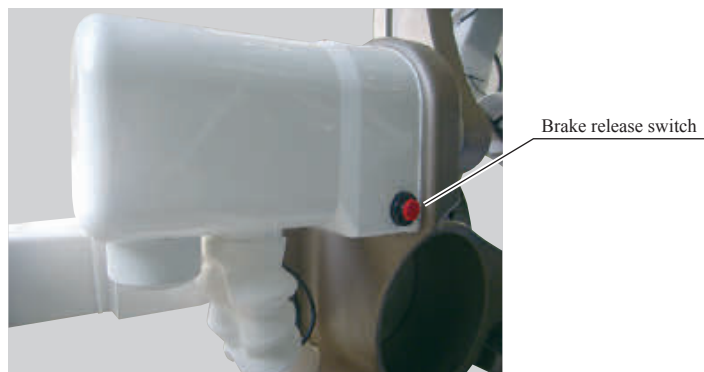

As the robot is put in the emergency stop state, the robot drive power is shut down. However, the axis cannot be moved since the brake is activated. So, release the brake, and then push the axis by hand to move it.



#### WARNING

THE  $\alpha$ -AXIS,  $\beta$ -AXIS OR  $\gamma$ -AXIS WILL SLIDE DOWNWARD WHEN THE BRAKE IS RELEASED, CAUSING A HAZARDOUS SITUATION.

- BEFORE RELEASING THE BRAKE, BE SURE TO PLACE A SUPPORT UNDER THE  $\alpha$ -AXIS,  $\beta$ -AXIS OR  $\gamma$ -AXIS SO THAT IT WILL NOT SLIDE DOWN.
- WHEN RELEASING THE BRAKE, BE CAREFUL NOT TO LET YOUR BODY GET CAUGHT BETWEEN THE MOVABLE BASE AND THE INSTALLATION BASE.



#### CAUTION

Release the brake axis-by-axis.



#### NOTE

For details about the brake release wire connector, see “4.2 Wiring the brake release wire connector” in Chapter 2 of the Installation Manual.

## 6. Using the robot safely

### 6.1 Robot protective functions

#### 1. Soft limits

Soft limits can be set on each axis to limit the working envelope in manual operation after return-to-origin and during automatic operation. The working envelope is the area limited by soft limits.



#### WARNING

SOFT LIMIT FUNCTION IS NOT A SAFETY-RELATED FUNCTION INTENDED TO PROTECT THE HUMAN BODY. ENSURE SAFETY BY INSTALLING A SAFETY ENCLOSURE AND SO ON.

#### 2. $\alpha$ -axis, $\beta$ -axis and $\gamma$ -axis brakes

An electromagnetic brake is installed on the  $\alpha$ -axis,  $\beta$ -axis and  $\gamma$ -axis to prevent them from sliding downward when the servo is OFF.



#### WARNING

THE  $\alpha$ -AXIS,  $\beta$ -AXIS OR  $\gamma$ -AXIS WILL SLIDE DOWNWARD WHEN THE BRAKE IS RELEASED, CAUSING A HAZARDOUS SITUATION. TAKE ADEQUATE SAFETY MEASURES BY TAKING THE WEIGHT AND SHAPE INTO ACCOUNT.

- BEFORE RELEASING THE BRAKE AFTER PRESSING THE EMERGENCY STOP BUTTON, PLACE A SUPPORT UNDER THE  $\alpha$ -AXIS,  $\beta$ -AXIS OR  $\gamma$ -AXIS SO THAT IT WILL NOT SLIDE DOWN.
- WHEN PERFORMING TASKS (DIRECT TEACHING, ETC.) WITH THE BRAKE RELEASED, BE CAREFUL NOT TO LET YOUR BODY GET CAUGHT BETWEEN THE MOVABLE BASE AND THE INSTALLATION BASE.

### 6.2 Residual risk

To ensure safe and correct use of OMRON robots, System integrators and/or end users implement the machinery safety design that conforms to ISO12100 or JIS9700-1/2.

Residual risks for OMRON robots are described in the DANGER or WARNING instructions provided in each chapter and section. So, read them carefully.

### 6.3 Special training for industrial robot operation

Operators or persons who handle the robot for tasks such as for teaching, programming, movement checks, inspections, adjustments, and repairs must receive appropriate training and also have the skills needed to perform the job correctly and safely. They must also read the manual carefully to understand its contents before attempting the robot operation or maintenance.

Tasks related to industrial robots (teaching, programming, movement check, inspection, adjustment, repair, etc.) must be performed by qualified persons who meet requirements established by local regulations and safety standards for industrial robots.

**Comparison of terms used in this manual with ISO**

<b>This manual</b>	<b>ISO 10218-1</b>	<b>Note</b>
<b>Maximum movement range</b>	maximum space	Area limited by mechanical stoppers.
<b>Movement range</b>	restricted space	Area limited by movable mechanical stoppers.
<b>Working envelope</b>	operational space	Area limited by software limits.
<b>Within safety enclosure</b>	safeguarded space	





# Warranty

For information on the warranty period and terms, please contact our distributor where you purchased the product.

## ■ This warranty does not cover any failure caused by:

1. Installation, wiring, connection to other control devices, operating methods, inspection or maintenance that does not comply with industry standards or instructions specified in the OMRON manual;
2. Usage that exceeded the specifications or standard performance shown in the OMRON manual;
3. Product usage other than intended by OMRON;
4. Storage, operating conditions and utilities that are outside the range specified in the manual;
5. Damage due to improper shipping or shipping methods;
6. Accident or collision damage;
7. Installation of other than genuine OMRON parts and/or accessories;
8. Modification to original parts or modifications not conforming to standard specifications designated by OMRON, including customizing performed by OMRON in compliance with distributor or customer requests;
9. Pollution, salt damage, condensation;
10. Fires or natural disasters such as earthquakes, tsunamis, lightning strikes, wind and flood damage, etc;
11. Breakdown due to causes other than the above that are not the fault or responsibility of OMRON;
12. Electrical shock when the user installs the actuator, etc. on the movable base or end effector in the 3-axis specifications.

## ■ The following cases are not covered under the warranty:

1. Products whose serial number or production date (month & year) cannot be verified.
2. Changes in software or internal data such as programs or points that were created or changed by the customer.
3. Products whose trouble cannot be reproduced or identified by OMRON.
4. Products utilized, for example, in radiological equipment, biological test equipment applications or for other purposes whose warranty repairs are judged as hazardous by OMRON.

## **WARRANTY**

**OMRON's exclusive warranty is that the products are free from defects in materials and workmanship for a period of one year after the date of manufacturing as shown on the product serial number plate.**

**OMRON MAKES NO WARRANTY OR REPRESENTATION, EXPRESS OR IMPLIED, REGARDING NONINFRINGEMENT, MERCHANTABILITY, OR FITNESS FOR PARTICULAR PURPOSE OF THE PRODUCTS. ANY BUYER OR USER ACKNOWLEDGES THAT THE BUYER OR USER ALONE HAS DETERMINED THAT THE PRODUCTS WILL SUITABLY MEET THE REQUERIMENTS OF THEIR INTENDED USE. OMRON DISCLAIMS ALL OTHER WARRANTIES, EXPRESS OR IMPLIED.**

## **LIMITATIONS OF LIABILITY**

**OMRON SHALL NOT BE RESPONSIBLE FOR SPECIAL, INDIRECT OR CONSEQUENTIAL DAMAGES, LOSS OF PROFITS OR COMERCIAL LOSS IN ANY WAY CONNECTED WITH THE PRODUCTS, WETHER SUCH CLAIM IS BASED ON CONTRACT, WARRANTY, NEGLIGENCE OR STRICT LIABILITY.**

**In no event shall the responsibility of OMRON for any act exceed the individual price of the product on which liability is asserted.**

**IN NO EVENT SHALL OMRON BE RESPONSIBLE FOR WARRANTY, REPAIR OR OTHER CLAIMS REGARDING THE PRODUCTS UNLESS OMRON'S ANALYSIS CONFIRMS THAT THE PRODUCTS WERE PROPERLY HANDLED, STORED, INSTALLED AND MAINTAINED AND NOT SUBJECT TO CONTAMINATION, ABUSE, MISUSE OR INAPPROPRIATE MODIFICATION OR REPAIR.**



# Chapter 1 Overview

## Contents

1. Overview

1-1



# 1. Overview



## WARNING

---

- ADJUSTMENT, MAINTENANCE AND REMOVAL OF ARMS, SHAFTS, OR THE  $\theta$ -AXIS ASSEMBLY REQUIRE SPECIALIZED TECHNICAL KNOWLEDGE AND SKILLS, AND ALSO MAY INVOLVE HAZARDS. THIS WORK MUST BE CARRIED OUT BY REFERENCING THIS MANUAL BY SUFFICIENTLY SKILLED AND QUALIFIED PERSONNEL IN ACCORDANCE WITH THE LAWS AND REGULATIONS OF EACH COUNTRY.
  - PLACE A CONSPICUOUS SIGN INDICATING THE ROBOT IS BEING ADJUSTED, TO PREVENT OTHERS FROM TOUCHING THE CONTROLLER SWITCH OR OPERATION PANEL.
  - IF A SAFETY ENCLOSURE HAS NOT YET BEEN PROVIDED RIGHT AFTER INSTALLATION OF THE ROBOT, ROPE OFF OR CHAIN OFF THE MOVEMENT RANGE AROUND THE MANIPULATOR IN PLACE OF A SAFETY ENCLOSURE, AND OBSERVE THE FOLLOWING POINTS.
    1. USE STABLE POSTS WHICH WILL NOT FALL OVER EASILY.
    2. THE ROPE OR CHAIN SHOULD BE EASILY VISIBLE BY EVERYONE AROUND THE ROBOT.
    3. PLACE A CONSPICUOUS SIGN PROHIBITING THE OPERATOR OR OTHER PERSONNEL FROM ENTERING THE MOVEMENT RANGE OF THE MANIPULATOR.
  - IF CHECKING OPERATION FOLLOWING ADJUSTMENT, REFER TO THE CONTROLLER USER'S MANUAL.
- 



## CAUTION

---

- Use only the lubricants specified by your distributors.
-



## Chapter 2

# Attaching, detaching and replacing the cover

## Contents

<b>1. Attaching, detaching and replacing the cover</b>	<b>2-1</b>
<b>1.1 Detaching or attaching the <math>\alpha</math>, <math>\beta</math>, <math>\gamma</math>-axes covers</b>	<b>2-1</b>
1.1.1 $\alpha$ , $\beta$ , $\gamma$ -axis cover removal procedure	2-2
1.1.2 $\alpha$ , $\beta$ and $\gamma$ -axis cover attachment procedure	2-7
<b>1.2 Detaching or attaching the <math>\theta</math>-axis cover</b>	<b>2-13</b>
1.2.1 $\theta$ -axis motor cover removal	2-14
1.2.2 $\theta$ -axis motor cover attachment	2-16





# 1. Attaching, detaching and replacing the cover

## 1.1 Detaching or attaching the $\alpha$ , $\beta$ , $\gamma$ -axes covers



### WARNING

- IF THE COVERS ARE REMOVED FOR MAINTENANCE WORK, BE SURE TO RETURN THEM TO THEIR ORIGINAL POSITIONS USING THE BOLTS USED TO SECURE THEM.
- IF ANY OF THE BOLTS BECOME LOST, USE THE SPECIFIED BOLTS AND QUANTITIES TO SECURE THE COVERS WHILE REFERRING TO THE FIG. BELOW.
- IF THE COVERS ARE NOT SECURED FIRMLY, NOISE MAY OCCUR, THE COVERS MAY DROP AND FLY OUT, HANDS MAY BECOME ENTANGLED IN THE DRIVE UNIT DURING TEACHING, OR COME INTO CONTACT WITH THE HOT DRIVE UNIT, CAUSING BURNS. OBSERVE THESE CAUTIONS STRICTLY TO PREVENT SUCH TROUBLE.



### CAUTION

The  $\alpha$ ,  $\beta$ , and  $\gamma$ -axis motor cover construction does not comply with IP67, and therefore the inside of the cover should be cleaned periodically. The motor and speed reduction gear inside the cover do comply with IP67.

R6Y3

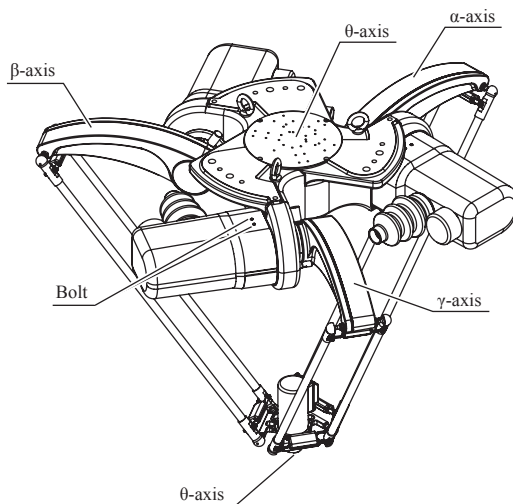

### 1. Replacement parts

	Part Name	OMRON Part No.	Part No. / Specs	Q'ty	Remarks
1	Motor cover	KDL-M2163-00x		2	$\beta$ , $\gamma$ -axes, affixed with electric shock caution label
2		KDL-M2163-10x		1	$\alpha$ -axis, warning label
3	Seal	KDL-M2138-00x		1	Motor cover attachment part (*1)
4	Cover securing bolt	97080-05008	M5, length 8	2	(*1)
5	Brake release switch	KDL-M4851-00x		1	(*1)
6	Bracket	KDL-M1172-00x		1	Motor cover upper attachment (*1)
		KDL-M1173-00x		1	Motor cover lower attachment (*1)
7	Bracket securing bolt	91380-04020	M4, length 20	4	(*1)
8	Cap	KDL-M2165-00x		1	(*1)
9	Boot	KDL-M212A-00x		1	(*1)

\*1 : Quantity per cover

## 1.1.1 $\alpha$ , $\beta$ , $\gamma$ -axis cover removal procedure



### WARNING

WHEN HANDLING MOTORS, TAKE CARE TO AVOID ELECTRIC SHOCK OR BURNS OWING TO THE HEAT GENERATED BY THE MOTORS.

### 1 *Remove the duct, boot, and cap.*



### NOTE

The boot and cap are merely inserted when the robot is shipped.

### 2 *Disconnect the robot cable connector.*

### ▶ Step 1 *Duct, boot, and cap removal*



Boot removal



Cap removal

3 **Remove the M5 hex bolt from the top of the motor cover.**

▶ Step 3 Bolt removal



4 **Remove the cover a little.**  
Grasp the rear of the cover and pull it out while shaking it up and down to remove the cover a little. About 10mm of the rubber will come out (within 5mm when attached).

▶ Step 4 Temporarily removed cover



**NOTE**  
The inside of the cover will catch and so will not come off completely.

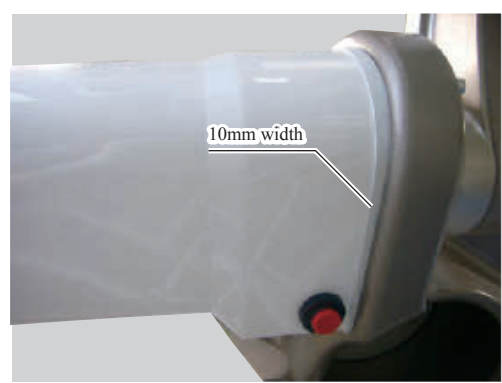
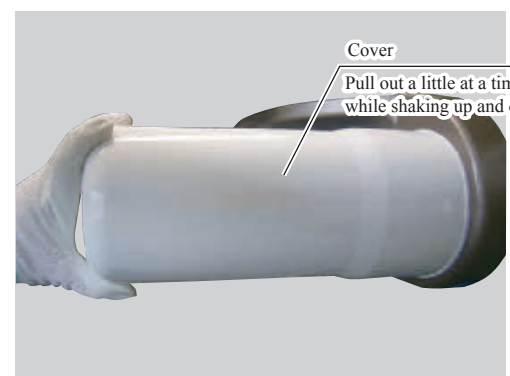

Cover bottom temporarily removed



Cover top temporarily removed

5

***Pull the cover out further.***

Make a gap between the cover and base by pulling the cover out further.



**NOTE**

The cover will catch at this point and so will not come off completely.

▶ **Step 5**

**Temporarily removed cover**



Cover bottom temporarily removed



Cover top temporarily removed

6

***Pull out the cover.***

Grasp the sides of the cover and push both sides so that the bottom deforms a little to pull out the cover. The clips on the inside near the switch will come free, making it easier to pull out the cover without it catching.

The motor connector will catch on the hole on the side of the cover, and so the cover should be shifted to avoid the connector. The switch on the inside will catch on the motor connector, and so the cover should be pulled out while trying to avoid the connector.

▶ **Step 6**

**Pull out the cover.**



## Clip structure

The cover clips will catch on the step of the bracket under the reduction gear. There are two steps, and the clips catch on the second step.

### Clip construction

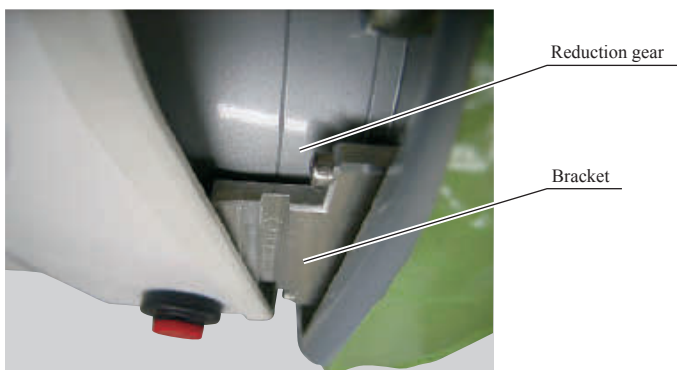

### Clip construction on inside

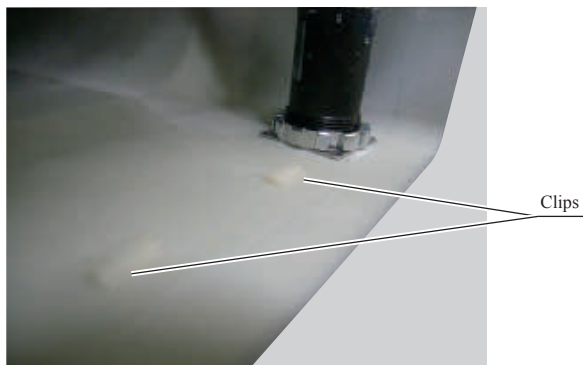

### Inside of removed cover

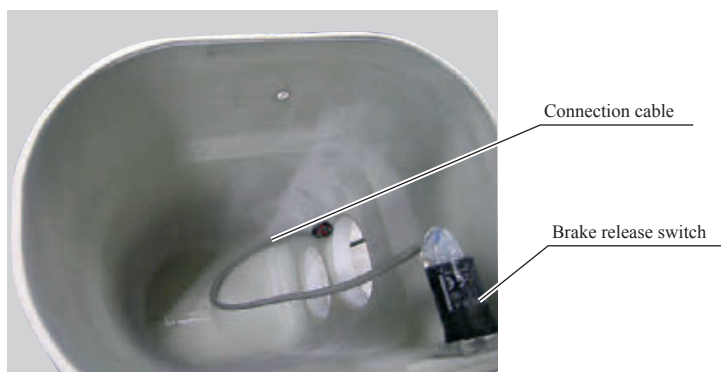

## 1.1.2 $\alpha$ , $\beta$ and $\gamma$ -axis cover attachment procedure

Attach the cover using the opposite of the procedure used for removal.



### WARNING

THE SAME TYPE OF MOTOR WIRE AND ENCODER WIRE IS USED FOR THE  $\alpha$ ,  $\beta$ , AND  $\gamma$ -AXES. CONNECT THE CABLES SO THAT THEY MATCH THE RESPECTIVE AXES AT THE CONTROLLER (DRIVER). THE ROBOT WILL NOT OPERATE CORRECTLY, RESULTING IN POSSIBLE DANGER IF THE CABLES ARE CONNECTED INCORRECTLY.

1

#### ***Insert the motor wire from smaller hole on the boot with small hole.***

The motor wire connector is larger and should therefore be inserted first.  
The motor wire connector should still be inserted first even if using L-shaped connectors.

2

#### ***Insert the encoder wire and brake release wire (prepared by user) from smaller hole on the boot.***



### CAUTION

The encoder wire must pass through the inside of the cover and therefore a sufficient length of wire should be inserted.

3

#### ***Pull the cover internal cables from the hole with the boot.***

On the outside of the cover is the cap, and the motor connector part should be the boot.

4

#### ***Connect the cover internal switch connector and brake release connector.***

Store the joint inside the cover.

The cable leading from the brake release connector should be prepared by the user.

### ▶ Step 1

#### **Insert the motor wire.**

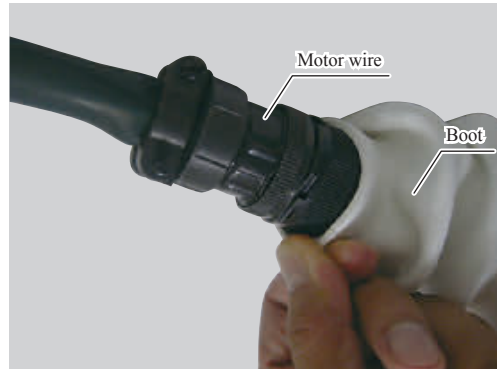

### ▶ Step 2

#### **Insert the encoder wire and brake release wire (prepared by user).**

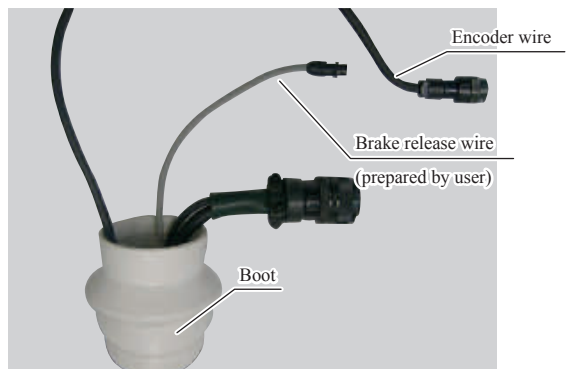

### ▶ Step 4

#### **Switch connector and brake release connector connection**



5

***Route the encoder wire.***

Insert the encoder wire only through the hole for the motor connector, and pull it out from the adjacent cap hole.

▶ **Step 5**

**Encoder wire routing**

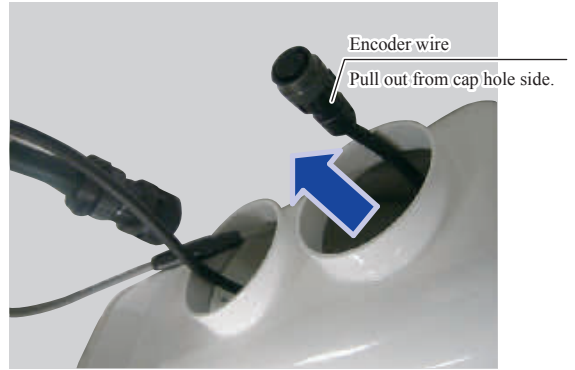
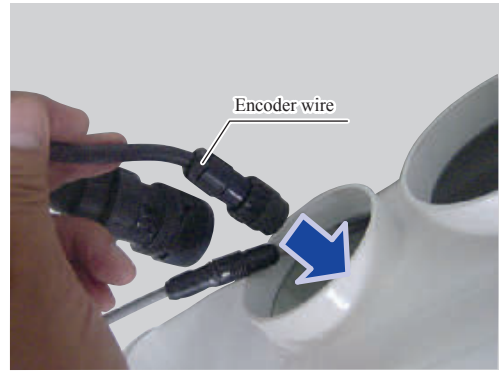



6

**Temporarily insert the motor cover.**

Insert the motor cover so that the internal switch does not interfere with the motor connector. Pull the brake release wire and encoder wire out from the gap next to the motor connector.

▶ Step 6

Temporary motor cover insertion

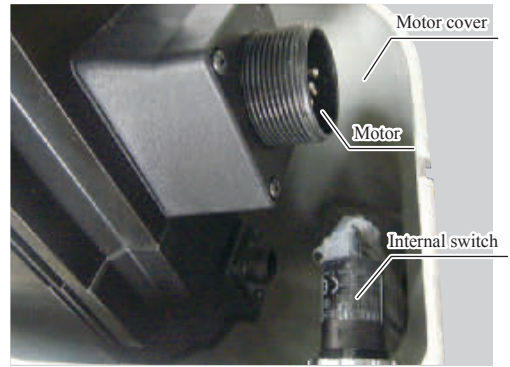

Cables removed when temporarily inserting cover

7 ***Insert the cover so that the rubber on the bottom fits in.***

There will be a gap when the cover catches on the first clip.

8 ***Insert the cover so that the rubber on the top fits in.***



**CAUTION**

Insert the rubber a little at a time, and avoid trying to force it in. If forced in, the rubber will end up deformed, making it difficult to attach the motor cover.

9 ***Push in the motor cover from the rear.***

The rubber at the bottom of the switch should protrude approximately 5mm, and the rubber at the top of the switch should protrude approximately 1mm.

▶ Step 7 **Gap**



Gap at top of cover



Gap at bottom of cover

▶ Step 8 **Insert the rubber.**



▶ Step 9 **Push in the motor cover.**

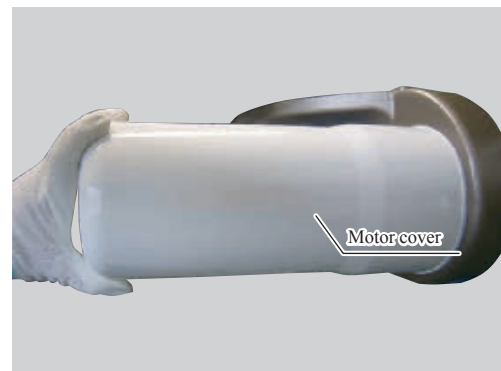

## 10 *Adjust the motor cover position and then secure with the M5 hex bolt(s).*

Adjust the motor cover position and then screw in two M5 hex bolts to secure.

Ensure that the motor cover has been securely attached.

It will not be possible to insert the bolts if the motor cover position and tapping positions for the M5 hex bolts are not aligned.

### ▶ Step 10 Motor cover attachment

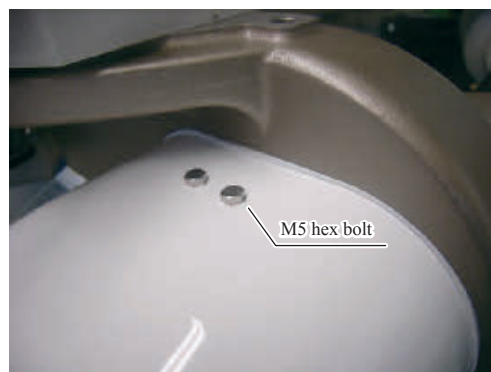

## 11 *Attach the robot cable connector.*



### WARNING

CONNECT THE  $\alpha$ ,  $\beta$  AND  $\gamma$ -AXIS ROBOT CABLES SO THAT THEY MATCH THE RESPECTIVE AXES AT THE CONTROLLER (DRIVER). THE ROBOT WILL NOT OPERATE CORRECTLY, RESULTING IN POSSIBLE DANGER IF THE CABLES ARE CONNECTED INCORRECTLY.

### ▶ Step 12 Boot, cap attachment



## 12 *Attach the boot and cap to the motor cover.*

## 13 *Attach the duct to the robot cable.*

Insert the robot cable into the notch on the duct.

The cable can be inserted easily by inserting a thick rod such as a flat screwdriver.

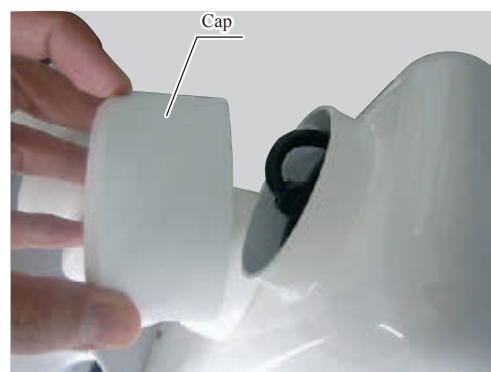

### ▶ Step 13 Duct attachment



14 *Attach the bracket to the robot cable.*

▶ Step 14 **Bracket attachment**

15 *Insert the bracket in the boot.*

16 *Insert the boot in the duct.*

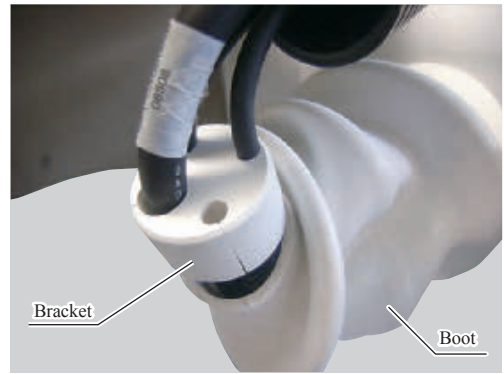

▶ Step 15 **Bracket insertion**



▶ Step 16 **Boot insertion**



## 1.2 Detaching or attaching the $\theta$ -axis cover

To detach the covers, remove the bolts and screws shown in the Fig. below.



### WARNING

- IF THE COVERS ARE REMOVED FOR MAINTENANCE WORK, BE SURE TO RETURN THEM TO THEIR ORIGINAL POSITIONS USING THE BOLTS USED TO SECURE THEM.
- IF ANY OF THE BOLTS BECOME LOST, USE THE SPECIFIED BOLTS AND QUANTITIES TO SECURE THE COVERS WHILE REFERRING TO THE FIG. BELOW.
- IF THE COVERS ARE NOT SECURED FIRMLY, NOISE MAY OCCUR, THE COVERS MAY DROP AND FLY OUT, HANDS MAY BECOME ENTANGLED IN THE DRIVE UNIT DURING TEACHING, OR COME INTO CONTACT WITH THE HOT DRIVE UNIT, CAUSING BURNS. OBSERVE THESE CAUTIONS STRICTLY TO PREVENT SUCH TROUBLE.

### R6Y31110L03067NJ5 / R6Y31110H03067NJ5 $\theta$ -axis

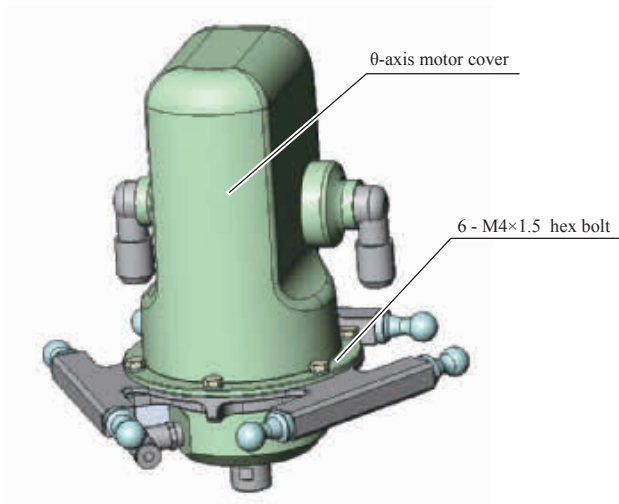

### 1. Replacement parts

	Part Name	OMRON Part No.	Part No. / Specs	Q'ty	Remarks
1	$\theta$ -axis motor cover	KDL-M182E-00x		1	
2	$\theta$ -axis motor cover attachment bolt	90780-04010	M4, length 10	6	
3	Washer	KDL-M1861-00x		6	
4	$\theta$ -axis cable (cover side)	KDL-M4813-00x		1	Motor cable
5		KDL-M4814-00x		1	Encoder cable
6	$\theta$ -axis cable securing bolt	91380-03006	M3, length 6	8	Secured to motor cover.
7	$\theta$ -axis cable (motor side)	KDL-M4811-00x		1	Motor cable
8		KDL-M4812-00x		1	Encoder cable
9	Earth bolt	97980-04308		2	

## 1.2.1 $\theta$ -axis motor cover removal



### CAUTION

When removing the  $\theta$ -axis motor cover, first disconnect the cable from the outside of the motor cover and then remove the moveable base from the  $\alpha$ ,  $\beta$  and  $\gamma$ -axis shafts before proceeding. There is a risk of bodily injury if the cable is damaged or a robot malfunction occurs inside the robot movement range.

- 1 **Remove the M4 hex bolts securing the  $\theta$ -axis motor cover and moveable base.**

Loosen with a spanner and then remove.

- 2 **Lift the  $\theta$ -axis motor cover from the moveable base.**

- 3 **Disconnect the cable connectors inside the cover.**

Disconnect the motor cable connector and encoder cable connector.

- 4 **Remove the two earth bolts.**

- 5 **Remove the  $\theta$ -axis motor cover.**

Take care not to cover the washers attached to the  $\theta$ -axis motor cover.

### ▶ Step 1 M4 hex bolt removal



### ▶ Step 2-4 Inside the motor cover

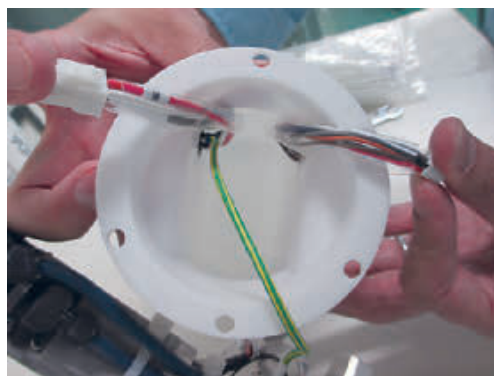
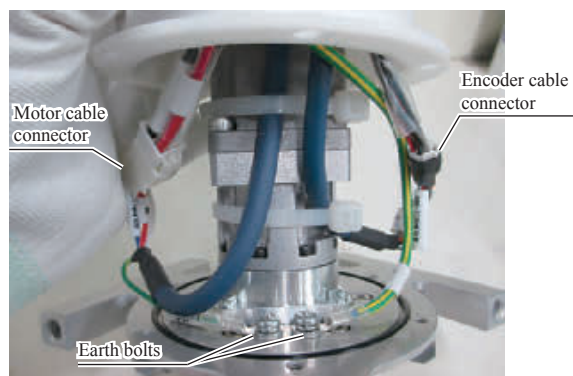

6

**Remove the cables from the inside of the  $\theta$ -axis motor cover (when replacing the cables inside the motor cover).**

The motor cable and encoder cable will both be removed.

Remove the four length 6 M3 hex bolts from the connector connection on the outside of the  $\theta$ -axis motor cover, and pull the cables toward the outside of the cover.

If replacing the cables inside the cover, also replace both of the connector O-rings.

▶ Step 6 Cable removal (motor cable side)

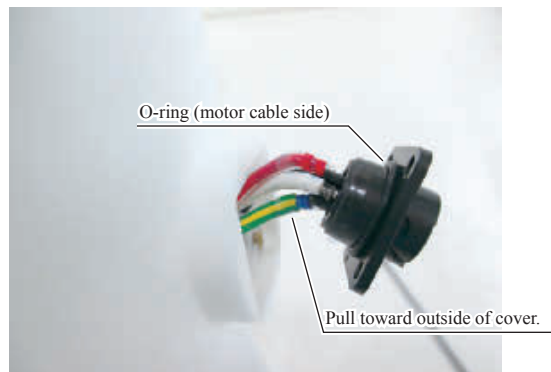

▶ Step 6 Cable removal (encoder cable side)

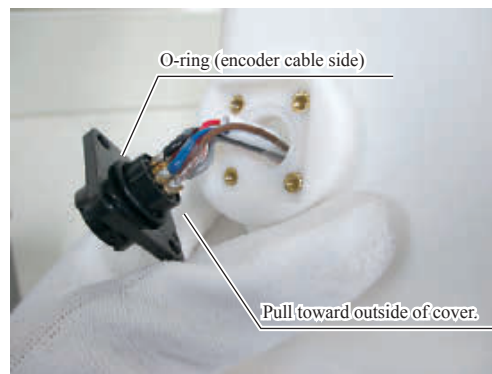



- 7 **Disconnect the motor cable and encoder cable from the  $\theta$ -axis motor (when replacing the motor, speed reduction gear).**

▶ Step 7 **Motor side motor cable, encoder cable removal**

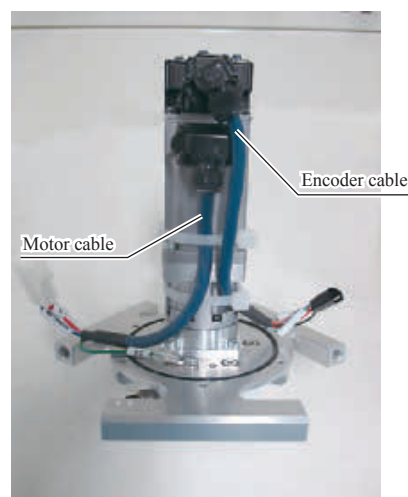

### 1.2.2 $\theta$ -axis motor cover attachment

Attach the cover using the opposite of the procedure used for removal.

- CAUTION** When attaching the  $\theta$ -axis motor cover, first disconnect the cable from the outside of the motor cover and then remove the moveable base from the  $\alpha$ ,  $\beta$  and  $\gamma$ -axis shafts before proceeding. There is a risk of bodily injury if the cable is damaged or a robot malfunction occurs inside the robot movement range.

▶ Step 1 **Motor side motor cable, encoder cable connection**

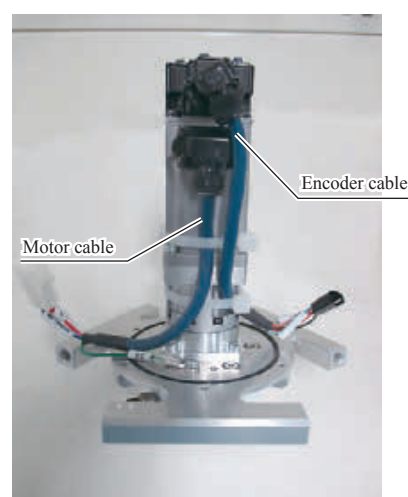

- 1 **Connect the motor cable and encoder cable to the  $\theta$ -axis motor (when replacing the motor, speed reduction gear).**

When attaching the  $\theta$ -axis motor cover, secure the cables with cable ties to prevent them from moving.

- 2 **Connect the cable (motor side) on the inside of the  $\theta$ -axis motor cover.**

Attach the cable connector so that it is facing the outside of the cover.

Ensure that the mark on the connector is facing upward.

If replacing the cable on the inside of the cover, fit an O-ring to the connector.

Secure the connector connection on the outside of the  $\theta$ -axis motor cover with the four length 6 M3 hex bolts.

- Tightening torque: 2Nm

▶ Step 2 **Cable connection (motor cable side)**

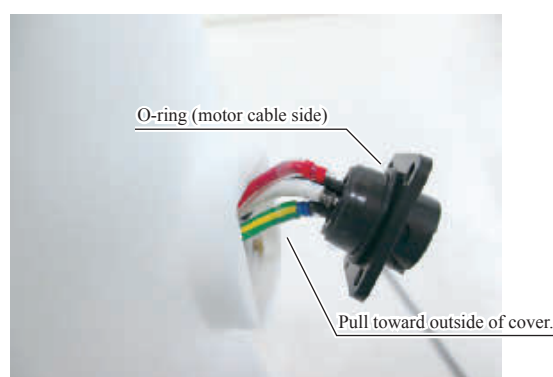

- CAUTION** If replacing cables on the inside of the cover, it will not be possible to guarantee waterproofing properties if the connector O-rings are not fitted, and therefore caution is advised.

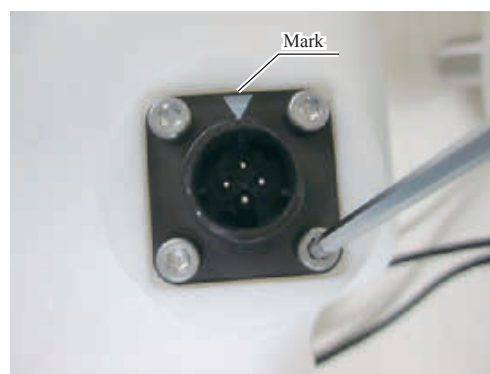



3

**Connect the cable at the encoder side in the same manner as that described in Step 2.**

Attach the cable connector so that the mark (groove) is facing upward.

**CAUTION**

If replacing cables on the inside of the cover, it will not be possible to guarantee waterproofing properties if the connector O-rings are not fitted, and therefore caution is advised.

- Tightening torque: 2Nm

## ▶ Step 3

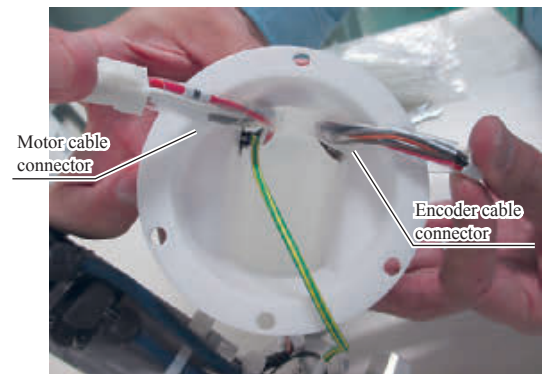
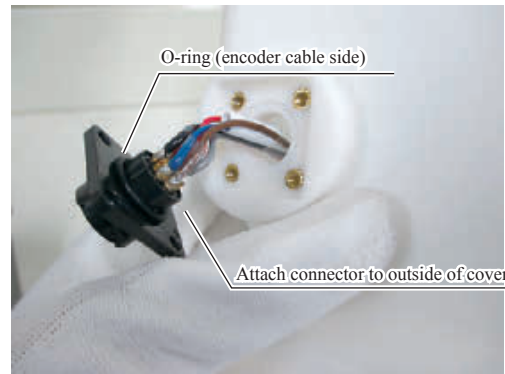
**Cable connection (encoder cable side)**

#### 4 **Connect the cable connectors to the inside of the cover.**

Connect both the motor cable connector and encoder cable connector.

#### 5 **Attach the two earth bolts.**



##### WARNING

FAILURE TO ATTACH THE EARTH BOLTS MAY RESULT IN ELECTRIC SHOCK.

#### 6 **Replace the $\theta$ -axis motor cover.**



##### CAUTION

- Route the cables on the inside of the  $\theta$ -axis motor cover so that they do not contact the O-rings. Prolonged contact with the O-rings may cause them to shift, leading to a possible loss of waterproofing properties.
- Do not bend the cables excessively, or apply excessive force when replacing the  $\theta$ -axis motor cover. Failure to observe this may result in cable damage.

#### 7 **Secure the $\theta$ -axis motor cover to the moveable base.**

Attach the washers to the  $\theta$ -axis motor cover, fit the M4 hex bolts to the washers, and then tighten with a spanner.

#### ► Step 4-6 **Cable routing inside motor cover**

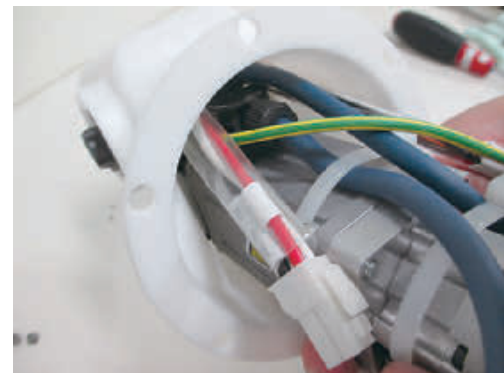
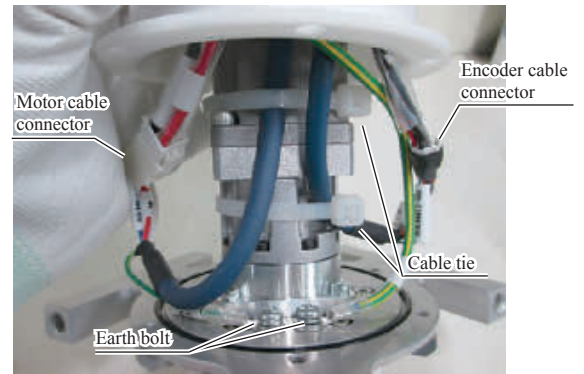

#### ► Step 7 **Washer attachment**



## Chapter 3 Periodic inspection

### Contents

1. Overview	3-1
2. Daily inspection	3-2
3. Monthly inspection	3-3
4. Six-month inspection	3-4



# 1. Overview

Daily and periodic inspection of the OMRON robot is essential in order to ensure safe and efficient operation. This chapter describes the periodic inspection items and procedures for the R6Y3 robots.

Periodic inspection includes:

- Daily inspection
- Monthly inspection
- 6-month inspection

Make sure that you thoroughly understand details of the inspection and follow the procedures and precautions explained in this chapter.



## WARNING

SPECIALIZED TECHNICAL KNOWLEDGE AND SKILLS ARE REQUIRED WHEN ARMS, SHAFTS AND THE  $\theta$ -AXIS ASSEMBLY ARE DETACHED TO ADJUST OR MAINTAIN. OPERATIONS PERFORMED BY WORKERS WHO DO NOT POSSESS THESE SPECIAL KNOWLEDGE AND SKILLS MAY LEAD TO DANGER. THIS WORK MUST BE CARRIED OUT BY REFERENCING THIS MANUAL BY SUFFICIENTLY SKILLED AND QUALIFIED PERSONNEL IN ACCORDANCE WITH THE LAWS AND REGULATIONS OF EACH COUNTRY.



## WARNING

- WHEN INSPECTION IS REQUIRED INSIDE THE SAFETY ENCLOSURE, ALWAYS TURN OFF THE CONTROLLER AND ALSO THE EXTERNAL SWITCH BOARD.
- IF THE INSPECTION OR MAINTENANCE PROCEDURE CALLS FOR OPERATION OF THE ROBOT, STAY OUTSIDE THE SAFETY ENCLOSURE.
- PLACE A SIGN INDICATING THE ROBOT IS BEING INSPECTED, TO KEEP OTHERS FROM OPERATING THE CONTROLLER SWITCH OR OPERATION PANEL.
- IF CHECKING OPERATION FOLLOWING INSPECTION, REFER TO THE CONTROLLER USER'S MANUAL.



## CAUTION

Use only the lubricants specified by your distributors.

## 2. Daily inspection

The following is an inspection list that must be performed every day before and after operating the robot.

### ■ Inspection to be performed with the controller turned off

Be sure to inspect with controller power off.

- 1 **Place a sign indicating the robot is being adjusted.**  
Place a sign indicating the robot is being inspected, to keep others from operating the controller switch.
- 2 **Perform the daily inspection.**  
Enter the safety enclosure and check the following points.

Checkpoint	Procedure
Robot cable User cable and wiring	Check for scratches, dents and excessive bend and kinks. (If the robot cable is damaged, contact your distributor.)
Regulator, joints, air tube, solenoid valve, air cylinder	<ul style="list-style-type: none"><li>• Check air pressure.</li><li>• Check for air leaks.</li><li>• Check drain.</li><li>• Check air filter for clogging or damage.</li></ul>
Robot exterior	Check for damage. (If a damage is found, contact your distributor.)
Plastic bearing (link ball sliding surface)	<ul style="list-style-type: none"><li>• Check for deformation, dents.</li><li>• Check that wear is 0.5mm or less.</li></ul>
Plastic bearing (spring mechanism plate sliding surface)	Check for deformation, breakage. (Check for cracks.)
Shaft	Check for deformation.
Spring cover	Check for damage. (Check for guide clip breakage.)
Inside spring cover (spring, plate, etc.)	<ul style="list-style-type: none"><li>• Check for deformation.</li><li>• Check the spring to see if it is overstretched.</li><li>• Check for M3 screw looseness.</li></ul>
$\theta$ -axis assembly seal	Check for any grease leaking from the coupling.

### ■ Adjustment and parts replacement



#### CAUTION

- If adjustment or replacement is deemed necessary following inspection, turn off the controller power before entering the safety enclosure to carry out work. If checking operation after work is complete, do so in accordance with “■ Inspection with the controller turned off” described above.
- If robot repair or part replacement is deemed necessary, contact your distributor. Such repair and part replacement requires specialized technical knowledge, and must not be carried out by the user.

# 3. Monthly inspection

This inspection is carried out once a month.

Pay attention to the following if applying grease to the  $\theta$ -axis assembly.



### WARNING

#### PRECAUTIONS WHEN HANDLING GREASE:

- INFLAMMATION MAY OCCUR IF THIS GETS IN THE EYES. BEFORE HANDLING THE GREASE, WEAR YOUR SAFETY GOGGLES TO ENSURE THE GREASE WILL NOT COME IN CONTACT WITH THE EYES.
- USE FOOD GREASE (CASSIDA GREASE, EPS2) WHEN USING THE ROBOT AT FOOD PLANTS.
- INFLAMMATION MAY OCCUR IF THE GREASE COMES INTO CONTACT WITH SKIN. BE SURE TO WEAR PROTECTIVE GLOVES TO PREVENT CONTACT WITH SKIN.
- DO NOT TAKE ORALLY OR EAT. (EATING WILL CAUSE DIARRHEA AND VOMITING.)
- KEEP OUT OF THE REACH OF CHILDREN.
- DO NOT HEAT THE GREASE OR PLACE NEAR AN OPEN FLAME SINCE THIS COULD LEAD TO SPARKS AND FIRES.

#### EMERGENCY TREATMENT:

- IF THIS GREASE GETS IN THE EYES, WASH LIBERALLY WITH PURE WATER FOR ABOUT 15 MINUTES AND CONSULT A PHYSICIAN FOR TREATMENT.
- IF THIS GREASE COMES IN CONTACT WITH THE SKIN, WASH AWAY COMPLETELY WITH SOAP AND WATER.
- IF TAKEN INTERNALLY, DO NOT INDUCE VOMITING BUT PROMPTLY CONSULT A PHYSICIAN FOR TREATMENT.

#### DISPOSING OF GREASE AND THE CONTAINER:

- PROPER DISPOSAL IS COMPULSORY UNDER FEDERAL, STATE AND LOCAL REGULATIONS. TAKE APPROPRIATE MEASURES IN COMPLIANCE WITH LEGAL REGULATIONS.

### ■ Inspection to be performed with the controller turned off

Be sure to perform the inspection with controller power off.

- 1 **Place a sign indicating the robot is being adjusted.**  
Place a sign showing that the robot is being inspected, to keep others from operating the controller switch.
- 2 **Perform the daily inspection.**  
Enter the safety enclosure and check the following points.

Checkpoint	Procedure
$\theta$ -axis assembly seal	Check for deformation, damage. Is there sufficient grease? If not, lightly apply some grease.

## 4. Six-month inspection

Take the following precautions when performing 6-month inspection.

### ■ Inspection to be performed with the controller turned off

Be sure to perform the inspection with controller power off.

- 1 **Place a sign indicating the robot is being adjusted.**  
Place a sign showing that the robot is being inspected, to keep others from operating the controller switch.
- 2 **Perform the daily inspection.**  
Enter the safety enclosure and check the following points.

Checkpoint	Procedure
Arm	Check for deformation, damage.
Link ball	Check for damage.
Major robot body bolts and screws (Those exposed on outside)	Check for looseness and tighten if necessary. (See the Table below.)

### Bolt tightening torque

Bolt size	Tightening torque (kgfcm)	Tightening torque (Nm)
M3 set screw	20	2
M3	20	2
M4	46	4.5
M4 4-axis specification $\alpha$ -axis arm cable clamp	20	2
M6	156	15.3
M8	380	37
M10	540	53
M12	1310	128

### ■ Adjustment and parts replacement



#### CAUTION

- If adjustment or replacement is deemed necessary following inspection, turn off the controller power before entering the safety enclosure to carry out work. If checking operation after work is complete, do so in accordance with “■ Inspection with the controller turned off” described above.
- If robot repair or part replacement is deemed necessary, contact your distributor. Such repair and part replacement requires specialized technical knowledge, and must not be carried out by the user.



# Chapter 4

# Adjusting the origin

## Contents

<b>1. Adjusting the origin</b>	<b>4-1</b>
1.1 Adjusting the $\alpha$ , $\beta$ and $\gamma$ -axis origin position	4-2
1.2 Adjusting the $\theta$ -axis origin position (4-axes specification only)	4-5



# 1. Adjusting the origin

The R6Y3 uses a calibration tool to mechanically adjust the origin position of the  $\alpha$ ,  $\beta$ ,  $\gamma$  and  $\theta$ -axes. Be sure to adjust the origin position in the following cases:

1. If the origin position is lost after disconnecting the robot cable connecting the controller with robot
2. If the origin position is lost after disconnecting the  $\theta$ -axis cables from the  $\theta$ -axis motor cover connectors and controller side robot cable connector
3. If the motor is replaced (same reason as above)
4. If any of the axis arms are removed



## CAUTION

- If any of the above situations occur after purchasing the robot, it is necessary to adjust the origin position(s) using the calibration tool. (The robot origin positions are adjusted at the factory.)
- Always use the calibration tool to perform origin position adjustment. If adjusted without using the calibration tool, the position will shift, resulting in abnormal robot operation, leading to robot damage and possible bodily injury.

This manual describes the origin position adjustment method using the calibration tool.

## 1. Replacement parts

	Part Name	OMRON Part No.	Part No. / Specs	Q'ty	Remarks
1	Origin position jig	KDL-M1501-YYY		1	For $\alpha$ , $\beta$ and $\gamma$ -axes
2		KDL-M1176-00x		1	For $\theta$ -axis
3	$\theta$ -axis origin position jig securing bolt	91312-05008	M5, length 8	2	

## 1.1 Adjusting the $\alpha$ , $\beta$ and $\gamma$ -axis origin position

The  $\alpha$ ,  $\beta$  and  $\gamma$ -axis origin positions are shown in the Fig. below.

Adjust each axis to its respective origin positions using the calibration jig.

### $\alpha$ , $\beta$ , $\gamma$ -axis origin positions

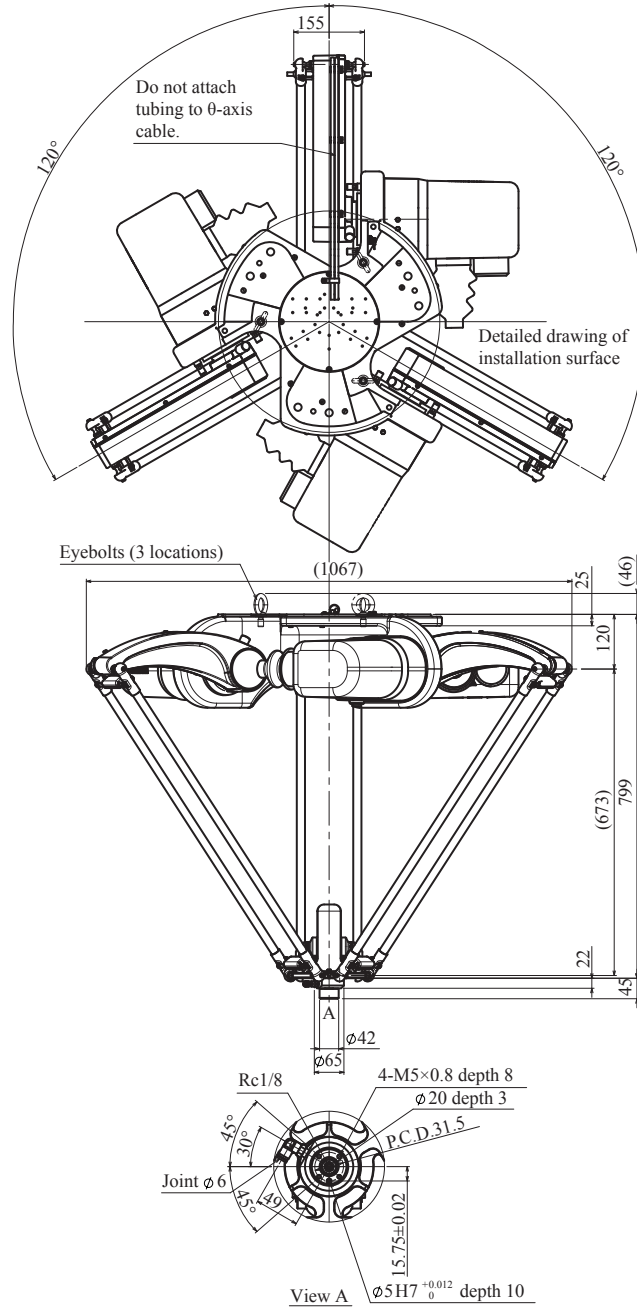

## Calibration tool ( $\alpha$ , $\beta$ , $\gamma$ -axes)

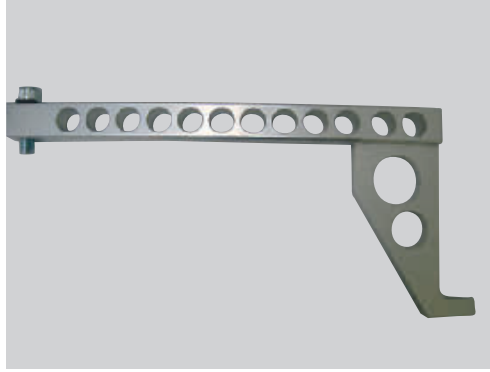

### 1 ***Post a sign indicating that the robot is being adjusted.***

Post a sign indicating that the robot is being adjusted to prevent others from turning on the controller power.

### 2 ***Enter the safety enclosure.***

### 3 ***Secure the calibration tool to the base.***

Secure the end of the calibration tool to the jig attachment holes on the base with the M12 hex socket head bolts provided.

The arm is moved at Step 5, and if it hits the calibration tool at that time, temporarily secure the tool, move the arm to a position above the tool at Step 5, apply the brake, secure the tool, and then perform Steps 4 and 5.

### 4 ***Release the motor brake for $\alpha$ -axis .***



#### **CAUTION**

When performing origin position adjustment, release the brake one axis at a time. Never release the brake for all three axes at the same time.

Doing so will result in a drop in origin position accuracy, leading to malfunctions.

#### ▶ Step 3 **Securing the calibration tool**

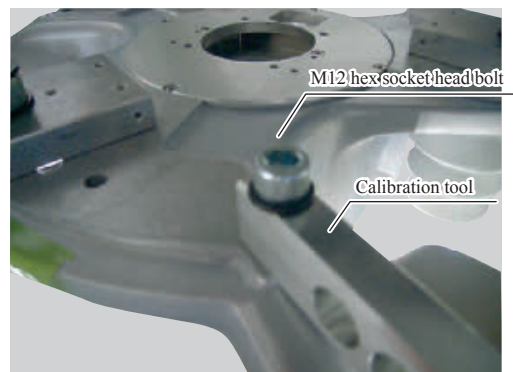

- 5 ***Move the arm slowly until the link ball on the end of the arm contacts the top of the calibration tool.***
- 6 ***Apply the motor brake for  $\alpha$ -axis .***
- 7 ***Remove the calibration tool from the base.***

By loosening the M12 hex socket head bolt on the end of the calibration tool, the tool comes away from the arm link ball. Confirm this and then remove the calibration tool.
- 8 ***Perform the procedure in Steps 3 to 7 for the  $\gamma$  and  $\beta$ -axes also.***

► Step 5 **Position link ball against tool.**

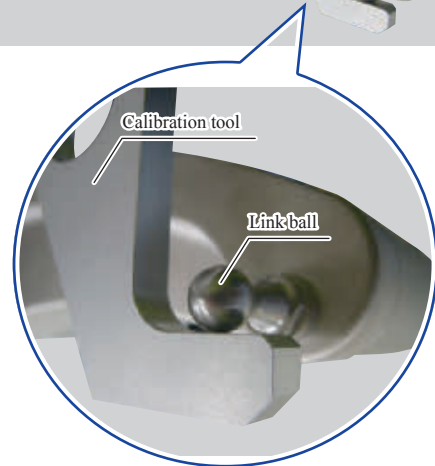
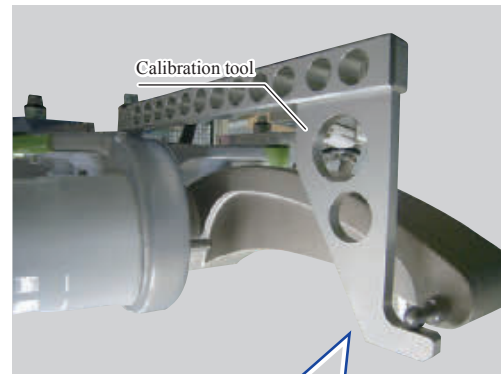

## 1.2 Adjusting the $\theta$ -axis origin position (4-axes specification only)

The  $\theta$ -axis origin position reference is the position in which the tool flange dowel hole is facing the  $\alpha$ -axis. The axis is adjusted to the reference position when shipped from the factory, however, the position may shift slightly. When installing the robot for the first time, it is necessary to use the calibration tool to adjust the origin position.



### CAUTION

The tool flange is fixed on 3-axes robots, and therefore it is only necessary to attach the moveable base in the correct direction. Refer to "1.1 Attaching the shafts, moveable base, and spring covers" in Chapter 5 for details on attaching the moveable base. With the 4-axes robot, it is necessary to adjust the  $\theta$ -axis origin position in addition to attaching the moveable base in the correct direction.

The  $\theta$ -axis origin position should generally never be changed. If changed, the axis may no longer move in the right direction.

- 1 **Post a sign indicating that the robot is being adjusted.**  
Post a sign indicating that the robot is being adjusted to prevent others from turning on the controller power.
- 2 **Enter the safety enclosure.**
- 3 **Secure the calibration tool.**  
The  $\theta$ -axis origin position is the position in which the tool flange dowel hole is facing the  $\alpha$ -axis.

### $\theta$ -axis origin position

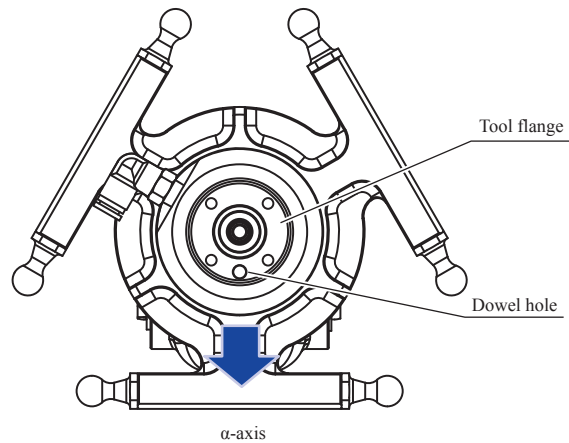

- 4 **Align the  $\theta$ -axis calibration tool pin with the tool flange dowel hole.**

5 *Secure at the two tool flange M5 holes.*

**Securing the calibration tool**

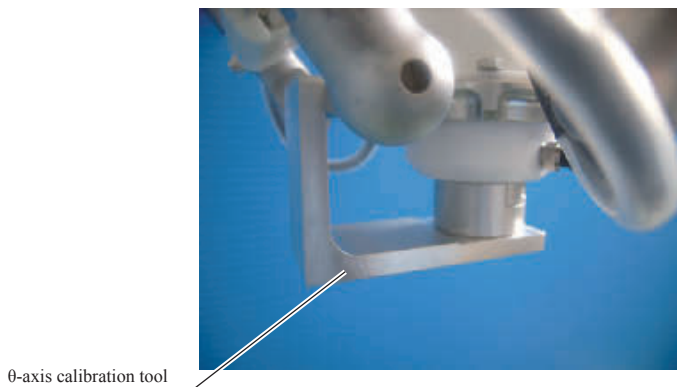
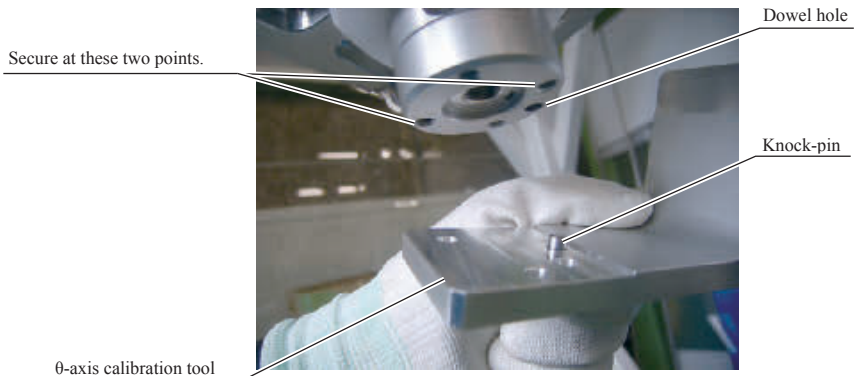



## Chapter 5

# Shaft, moveable base and spring cover replacement

## Contents

<b>1. Shaft, moveable base and spring cover replacement procedure</b>	<b>5-1</b>
<b>1.1 Detaching the shafts, moveable base and spring cover</b>	<b>5-1</b>
<b>1.2 Attaching the shafts, moveable base and spring covers</b>	<b>5-4</b>
1.2.1 R6Y30110S03067NJ5 (3-axes specification)	5-4
1.2.2 R6Y31110L03067NJ5, R6Y31110H03067NJ5 (4-axes specification)	5-6
<b>2. Moveable base link ball replacement</b>	<b>5-9</b>



# 1. Shaft, moveable base and spring cover replacement procedure

## 1. Replacement parts

	Part Name	OMRON Part No.	Part No. / Specs	Q'ty	Remarks
1	Spring cover	KDL-M1542-00x		2	Upper side cover (*1)
2		KDL-M1543-00x		2	Lower side cover (*1)
3	Shaft	KDL-M150A-00x		6	$\alpha$ , $\beta$ and $\gamma$ -axes (3-axes specification)
4				4	$\beta$ and $\gamma$ -axes (4-axes specification)
5		KDL-M150E-00x		1	$\alpha$ -axis motor cable side (4-axes specification)
6		KDL-M150F-00x		1	$\alpha$ -axis encoder cable side (4-axes specification)
7	Cap	KDL-M1562-00x		4	Shaft filler plug (*1)

\*1 : Quantity per axis

## 1.1 Detaching the shafts, moveable base and spring cover

With the R6Y31110L03067NJ5 and R6Y31110H03067NJ5 (4-axes specification) robots, the cable protrudes from the  $\alpha$ -axis shaft. Shaft, moveable base, and spring cover detachment is the same as that for the 3-axes specification robot.



### CAUTION

It is necessary to enter the safety enclosure in order to detach or attach the shafts, moveable base, or spring covers, and therefore the controller power must be turned off beforehand.

- 1** *Post a sign indicating that the robot is being adjusted.*  
Post a sign indicating that the robot is being adjusted to prevent others from turning on the controller power.
- 2** *Enter the safety enclosure.*

3

**Remove the spring covers.**

There are a total of six spring covers: one at the arm, and one at the moveable base for each of the three axes.

There is a top spring cover and bottom spring cover, with the top cover being wider.

The spring covers are held together with clips on the inside.

Pull the bottom cover down at the arm side and pull the top cover up at the moveable base side to remove the spring cover.



**CAUTION**

Use both hands when removing the spring covers. Use one hand for removal and the other to stop the bottom cover falling.

If the spring cover falls and is damaged, the robot may operate abnormally.

4

**Remove the end effector.**

Refer to “6. Attaching the end effector” in Chapter 2 of the installation manual for details.

5

**Disconnect the air tube from the joint on the user tubing.**



**CAUTION**

Do not carry out replacement work with the air tube still attached to the joint on the user tubing.

By doing so, the air tube may bend.

6

**Ensure that the  $\theta$ -axis cable can be disconnected from the  $\alpha$ -axis arm. (R6Y31110L03067NJ5, R6Y31110H03067NJ5 only)**

The cable is secured at three locations on the  $\alpha$ -axis arm. Remove the cable ties, and then remove the plastic block holding the cable in place.



**CAUTION**

Do not pull the cable too hard when removing. If pulled too hard, the cable may be damaged, resulting in possible robot malfunction.

**Step 3**

**Spring cover removal**

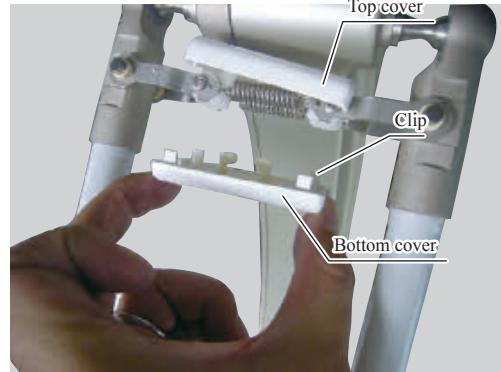
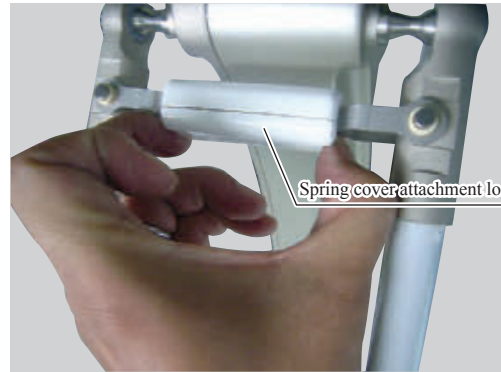

Arm side

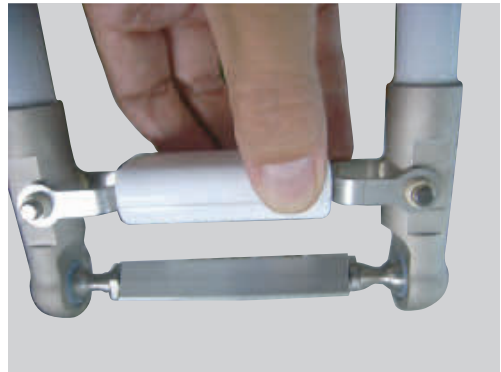

Base side

**Step 6**

**Arm side cable**

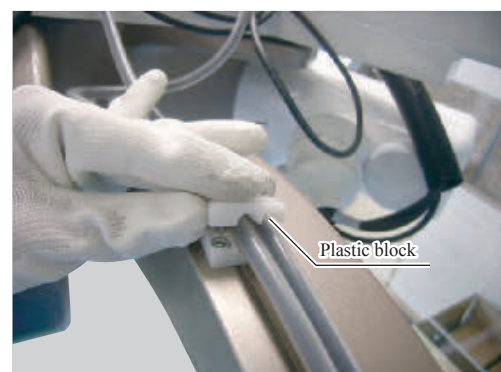
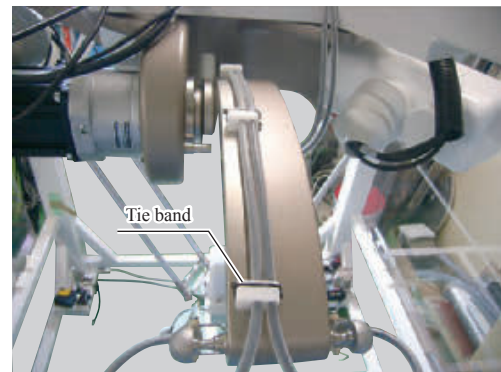

7 **Disconnect the cable at the moveable base side from the motor cover.**  
**(R6Y31110L03067NJ5, R6Y31110H03067NJ5 only)**

The cable is disconnected by rotating the connector as shown with the arrow on the cable side connector and then disconnecting it from the motor cover.

8 **Remove the shafts.**

Remove the shafts from the arm and moveable base link balls.

When doing so, the link balls can be stretched by hand at the end of the shaft as shown in the Fig. on the right.

When removing the shafts from the moveable base, disconnect the  $\theta$ -axis robot cable from the motor beforehand.



**CAUTION**

- Remove the spring covers before removing the shafts. The spring covers may be damaged if work is carried out without removing them.
- Take care not to pull the springs on the shafts too much. If stretched too far, the springs may not return to their original shape, possibly leading to abnormal robot movement.
- With the R6Y31110L03067NJ5 and R6Y31110H03067NJ5, a cable is attached to the  $\alpha$ -axis shaft. If the  $\alpha$ -axis shaft is removed from the moveable base without disconnecting the  $\theta$ -axis cable from the motor, the cable will be pulled and possibly damaged, leading to potential defects. Furthermore, care should be taken not to drop the moveable base.

▶ **Step 7**

**Cable removal at moveable base side**

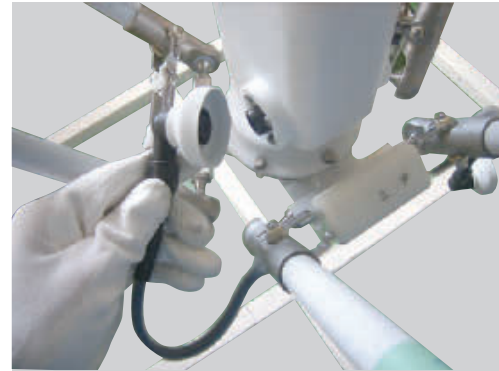

▶ **Step 8**

**Shaft removal**



## 1.2 Attaching the shafts, moveable base and spring covers



### CAUTION

It is necessary to enter the safety enclosure in order to detach or attach the shafts, moveable base, or spring covers, and therefore the controller power must be turned off beforehand.

### 1.2.1 R6Y30110S03067NJ5 (3-axes specification)

The replacement procedure for the shafts, moveable base, and spring covers is the same as that for the  $\alpha$ ,  $\beta$  and  $\gamma$ -axes.

#### 1 **Post a sign indicating that the robot is being adjusted.**

Post a sign indicating that the robot is being adjusted to prevent others from turning on the controller power.

#### 2 **Enter the safety enclosure.**

#### 3 **Attach the shafts.**

Attach the shafts while ensuring to hook the shaft plastic bearings onto the arm and moveable base link balls. The link balls can be stretched by hand at the end of the shaft as shown in the Fig.

The depression on the shafts for spring cover attachment should face upward.

The moveable base attachment direction is as shown in the Fig. Refer to "1.2 Adjusting the  $\theta$ -axis origin position" in Chapter 4 for details.



### CAUTION

By attaching the shafts with hands placed anywhere other than the shaft end, the joint between the shaft and shaft end may deform, possibly leading to malfunction. Ensure to place hands on the end of the shaft as shown in the Fig. on the right.

Take care not to pull the springs on the shafts too much. If stretched too far, the springs may not return to their original shape, possibly leading to malfunction.

#### ▶ Step 3 Shaft attachment

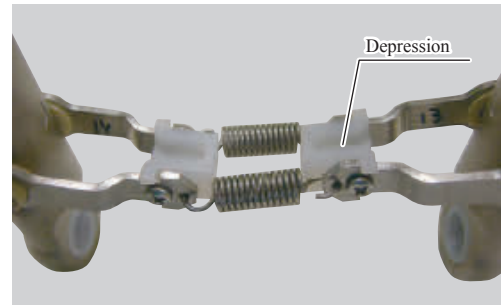

Moveable base side



Arm side

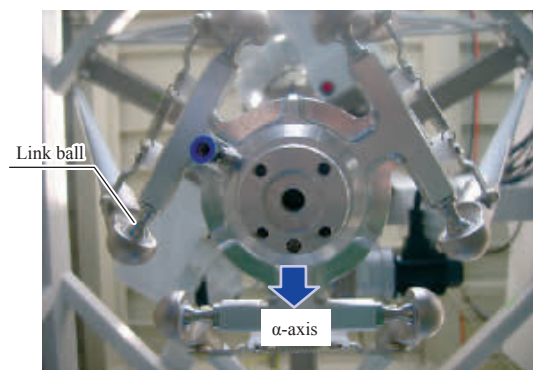

4

***Attach the spring covers.***

There are a total of six spring covers: one at the arm, and one at the moveable base for each of the three axes.

The top and bottom positions of the spring covers are fixed.

If the shaft direction is correct at Step 3, the cover attached at the top will be wide as shown in the Fig.

The spring covers come as a top and bottom set when shipped. Attach the covers so that they snap together at the guide clips.



Step 4

**Spring cover attachment**

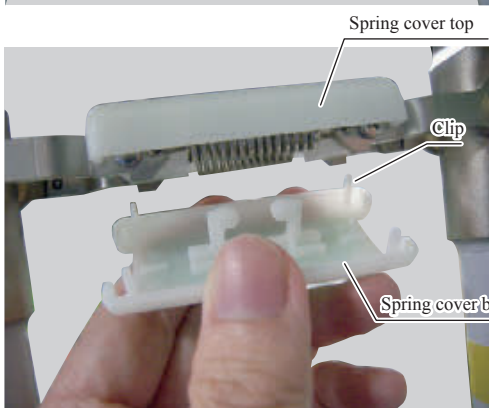
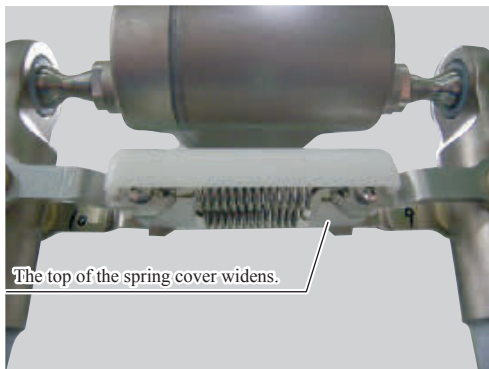



## 1.2.2 R6Y31110L03067NJ5, R6Y31110H03067NJ5 (4-axes specification)

With the R6Y31110L03067NJ5 and R6Y31110H03067NJ5 (4-axes specification) robots, the cable protrudes from the  $\alpha$ -axis shaft.

Shaft, moveable base, and spring cover attachment is the same as that for the 3-axes specification robot.

### 1 **Post a sign indicating that the robot is being adjusted.**

Post a sign indicating that the robot is being adjusted to prevent others from turning on the controller power.

### 2 **Enter the safety enclosure.**

### 3 **Attach the shafts.**

Attach the shafts while ensuring to hook the shaft plastic bearings onto the arm and moveable base link balls. The link balls can be stretched by hand at the end of the shaft as shown in the Fig.

The depression on the shafts for spring cover attachment should face upward.

The moveable base attachment direction is as shown in the Fig. Refer to "1.2 Adjusting the  $\theta$ -axis origin position" in Chapter 4 for details.



#### CAUTION

By attaching the shafts with hands placed anywhere other than the shaft end, the joint between the shaft and shaft end may deform, possibly leading to malfunction. Ensure to place hands on the end of the shaft as shown in the Fig. on the right.

Take care not to pull the springs on the shafts too much. If stretched too far, the springs may not return to their original shape, possibly leading to malfunction.

### Step 3 Shaft attachment

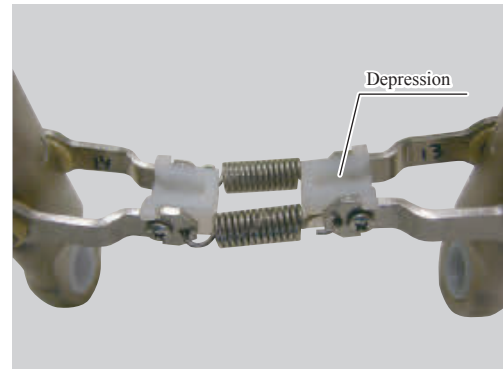

Moveable base side



Arm side

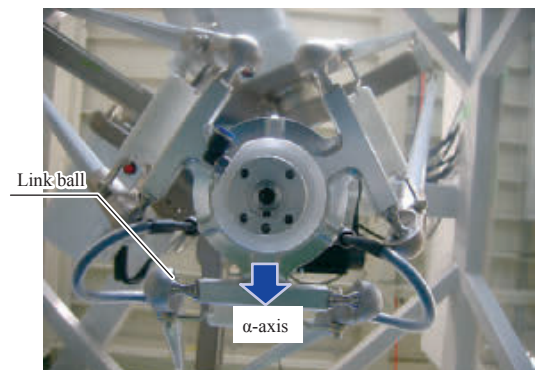



4

***Attach the spring covers.***

There are a total of six spring covers: one at the arm, and one at the moveable base for each of the three axes.

The top and bottom positions of the spring covers are fixed.

If the shaft direction is correct at Step 3, the cover attached at the top will be wide as shown in the Fig. below.

The spring covers come as a top and bottom set when shipped. Attach the covers so that they snap together at the guide clips.

5

***Route the arm side cable and insert it into the plastic block on the arm.***

Route the cables along the  $\alpha$ -axis arm to the robot base while trying not to bend them too much.

▶ Step 4

**Spring cover attachment**

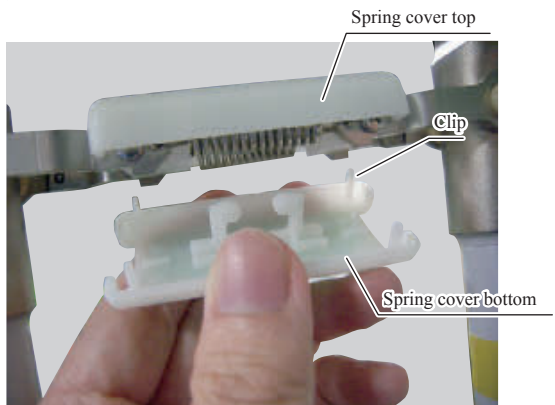
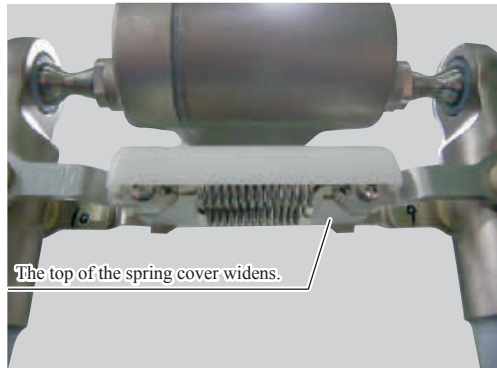

▶ Step 5

**Cable routing at arm side**



## 6 *Secure the attached cable with the plastic block.*

There are a total of three securing locations. Use two tie bands for each location, and secure the cables with the plastic block as shown.



### CAUTION

Be careful not to pull the cables too much. If pulled too much, the cables may be damaged, resulting in possible robot malfunction.

## 7 *Attach the cable at the moveable base side to the motor cover.*

Ensure that the moveable base and  $\alpha$ -axis shaft attachment directions are correct.

Align the arrow on the cable connector with the connector mark on the motor cover and attach.

Attach both the motor cable and encoder cable to their respective connectors.

### ▶ Step 6 **Securing the cables**

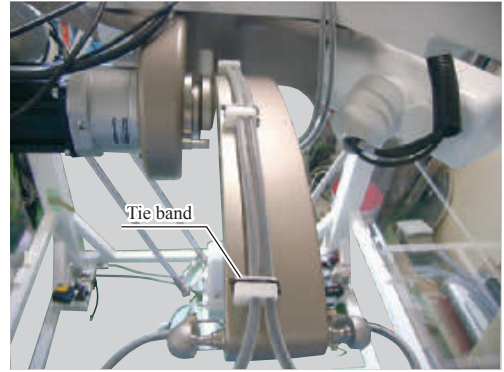
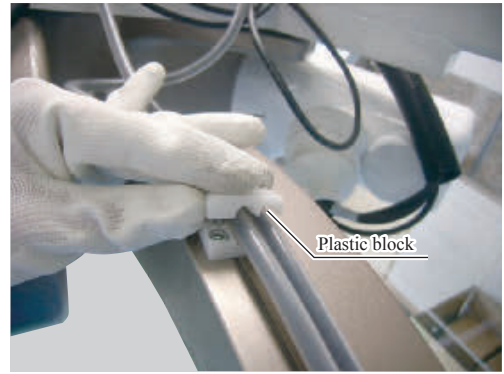

### ▶ Step 7 **Cable attachment at moveable base side**



## 2. Moveable base link ball replacement

The link ball attachment method is described below.

Remove the link balls using the opposite of the method used for attachment.

### 1. Replacement parts

	Part Name	OMRON Part No.	Part No. / Specs	Q'ty	Remarks
1	link ball	KDL-M152A-00x		6	Moveable base part

1 ***Apply a thin layer of Loctite screw lock to the link ball screw.***

Use Henkel Loctite 241 (blue).

2 ***Attach a link ball at six locations on the moveable base.***

▶ Step 2 **Link ball attachment**

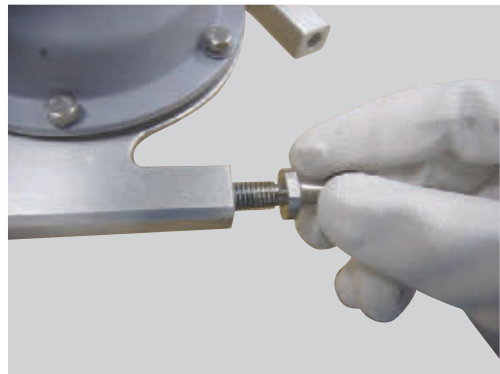

3 ***Tighten the link balls with a tool.***

• Tightening torque: 20Nm

▶ Step 3 **Tightening**

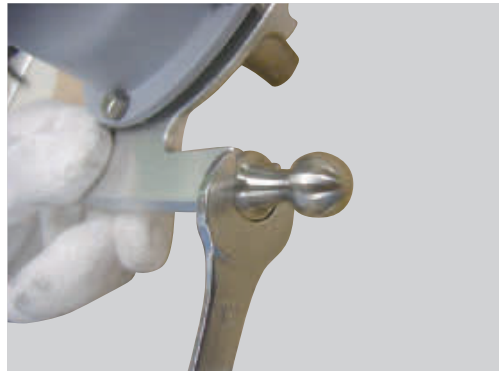



## Chapter 6

# Spring mechanism replacement

### Contents

<b>1. Spring mechanism replacement procedure</b>	<b>6-1</b>
1.1 Spring mechanism removal	6-1
1.2 Spring mechanism attachment	6-2



# 1. Spring mechanism replacement procedure

## 1. Replacement parts

	Part Name	OMRON Part No.	Part No. / Specs	Q'ty <sup>*1</sup>	Remarks
1	Plate	KDL-M1534-00x		8	
2	Spring	KDL-M152M-00x		4	
3	Plastic block	KDL-M153A-00x		4	
4	Screw	98980-03006	M3, length 6	8	

\*1 : Quantity per axis

## 1.1 Spring mechanism removal

- 1 **Remove the shaft from the arm and moveable base.**  
Refer to "Shaft, moveable base, and spring cover replacement" in Chapter 5 for details.
- 2 **Remove the M3 screws at four locations.**  
By removing the screws, the springs, plate assembly, and plastic blocks come free of the shaft.
- 3 **Remove the springs.**  
Perform this procedure only when replacing springs.
- 4 **Remove the press-fit plastic bearings.**  
Perform this procedure only when replacing plastic bearings.  
Refer to "Plastic bearing replacement" in Chapter 7 for details.

### ▶ Step 1 Shaft removed from arm and moveable base

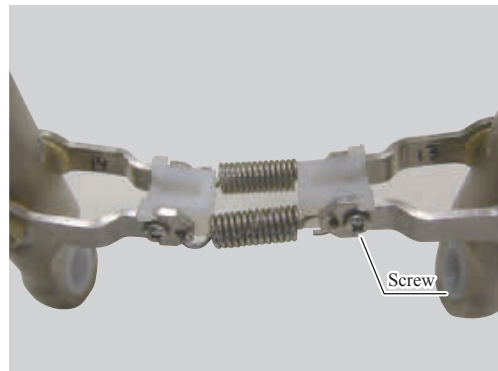

### ▶ Step 2 Screw removal

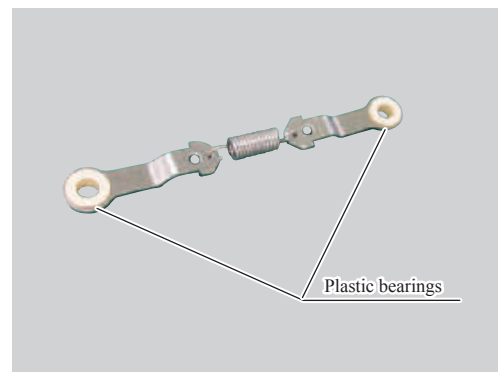

## 1.2 Spring mechanism attachment

- 1 **Press fit the plastic bearings into the plate.**  
Refer to “Plastic bearing replacement” in Chapter 7 for details.



### CAUTION

Pay attention to the attachment direction. It will not be possible to attach the shaft if the plate and plastic bearing directions are not as shown on the right.

- 2 **Attach the spring.**  
Ensure that the plates are bilaterally symmetrical. For two shafts, two of the assemblies shown on the right are required at the arm side, and two assemblies are required at the moveable base side.

- 3 **Secure the plastic blocks with M3 screws.**  
As shown on the right, press the protruding part of the plastic block against the protruding part of the plate, and then secure with the screws. Attach the plate to the other plastic block attachment surface on the other side after attaching to the shaft.



### CAUTION

Force is applied to the plastic when tightening, and therefore care should be taken to avoid over tightening.

### Step 1 Plastic bearing, plate

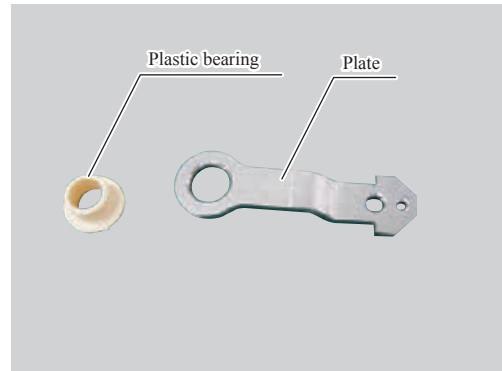

### Step 2 Spring attachment

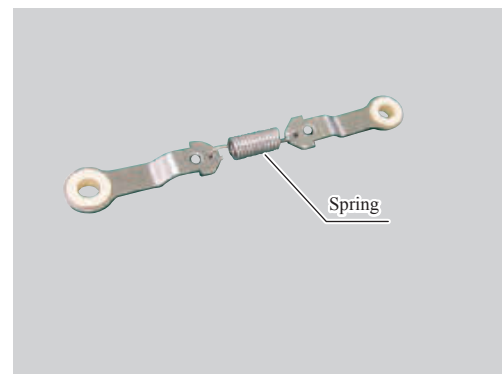

### Step 3 Securing the plastic blocks

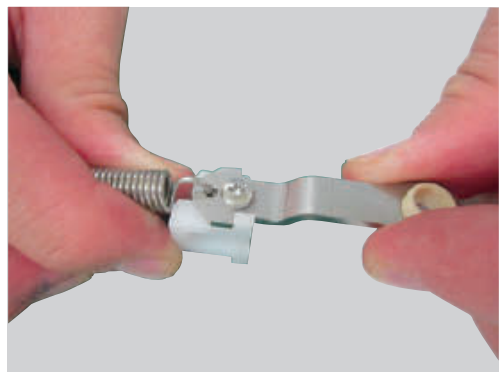
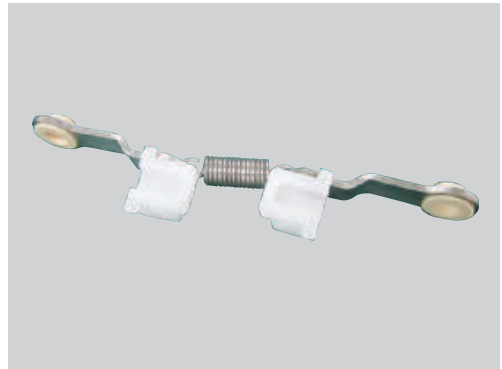



**4** *Attach the plate and plastic block assembly to the shaft.*

Insert the plastic bearing attached to the plate so that it catches on the shaft pin.



**NOTE**

The assembly is attached at both the arm side and moveable base side; however, the plastic block direction should be the same for both.

**5** *Attach the other plate and spring assembly (assembly without plastic block) to the shaft.*

**6** *Secure the plastic block with the M3 screws as described in Step 3.*

Attach so that the plate and plastic block are level.

**7** *Attach the plate and plastic block assembly on the opposite of the side already attached using the same procedure described in Steps 3 to 6.*

**Step 4** **Assembly attachment locations**

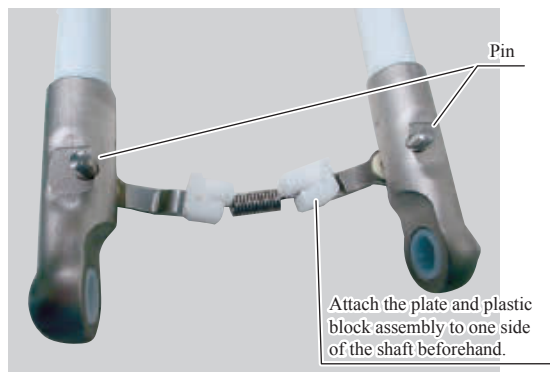

**Step 5** **Plate and spring assembly attachment**

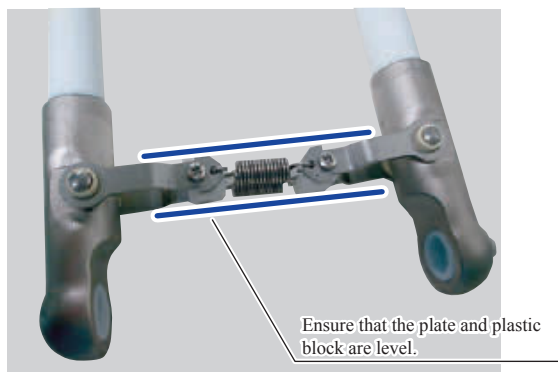



## Chapter 7

# Plastic bearing replacement

### Contents

<b>1. Plastic bearing replacement procedure</b>	<b>7-1</b>
1.1 Removing the plastic bearing from the link ball sliding part	7-1
1.2 Attach the jig with threaded screw to the tapping hole on the end of the shaft	7-2
1.3 Spring mechanism plate plastic bearing removal	7-4
1.4 Spring mechanism plate plastic bearing attachment	7-4
<b>2. Plastic bearing inspection</b>	<b>7-5</b>



# 1. Plastic bearing replacement procedure



## CAUTION

Plastic bearings are consumable parts and should therefore be replaced periodically.

## 1. Replacement parts

	Part Name	OMRON Part No.	Part No. / Specs	Q'ty	Remarks
1	Plastic bearing 1	KDL-M152K-00x		24	Spring mechanism
2	Plastic bearing 2	KDL-M152J-00x		12	Replace if wear 0.5mm or greater.

## 1.1 Removing the plastic bearing from the link ball sliding part

Plastic bearing replacement guideline: when amount of wear reaches 0.5mm

When replacing plastic bearings, be sure to check and take a note of the bearing depth, and periodically measure the amount of wear.

**1** *Remove the cap from the end of the shaft.*

The tapping hole becomes visible when the cap is removed.

▶ **Step 1** **Cap removal**

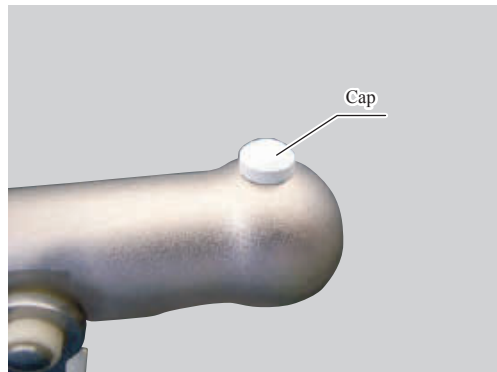

**2** *Insert an M6 bolt in the tapping hole on the end of the shaft.*

The tapping hole is located on the opposite side to that with the plastic bearing.

**3** *Push in the plastic bearing while tightening the M6 bolt with a hex wrench.*

By pushing in while tightening, the plastic bearing is pushed in and comes off.

▶ **Step 2-3** **Bolt attachment**

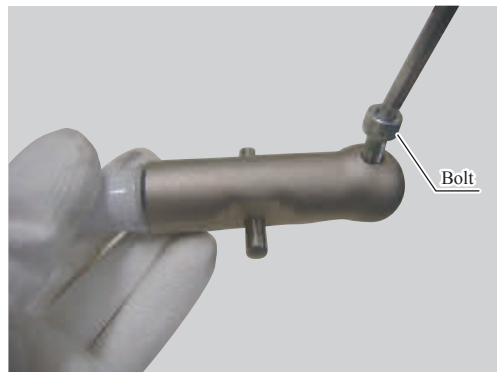

## 1.2 Attach the jig with threaded screw to the tapping hole on the end of the shaft

### 1 *Attach plastic bearing attachment jig 1.*

Attach the jig with thread to the tapping hole on the end of the shaft.

### 2 *While pressing the protruding part on the plastic bearing attachment jig 2 against the groove on plastic bearing, press into the plastic bearing attachment surface on the shaft side.*

Press the bearing attachment jig 2 horizontally against the attachment surface as shown on the right so as not to incline the plastic bearing.

#### ▶ Step 1 Plastic bearing attachment jig 1 attachment

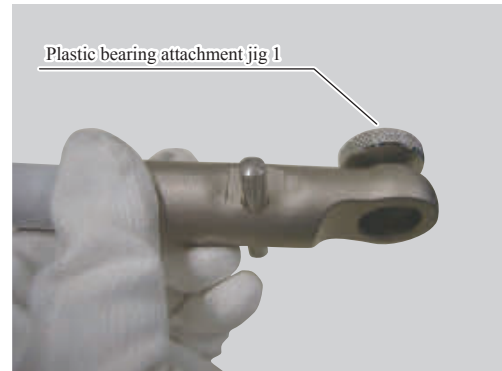

#### ▶ Step 2 Plastic bearing attachment jig 2 attachment



3 *Press in the plastic bearing with tool capable of gripping such as a pair of water pump pliers.*

4 *Remove plastic bearing attachment jig 1 from the shaft, and then attach the cap.*

▶ Step 3 **Press in the plastic bearing.**



After being pressed in (when attachment complete)

▶ Step 4 **Plastic bearing attachment condition and cap attachment**



### 1.3 Spring mechanism plate plastic bearing removal

- 1 **Push the plate down from above with the protruding part of the plastic bearing facing down.**

The plastic bearing will pop up, allowing it to be removed. If it still cannot be removed even after popping up, use a flat screwdriver or similar tool to remove it.



#### CAUTION

The bearing is press fit when attached, and should therefore be removed using a tool.

#### Step 1 Plastic bearing removal

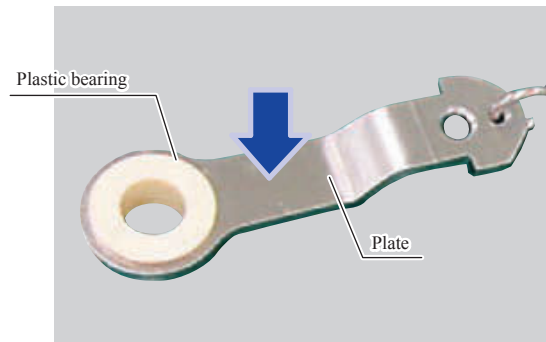

### 1.4 Spring mechanism plate plastic bearing attachment

- 1 **Pay attention to the plastic bearing attachment direction and attach by press fitting.**

Attach with the plastic bearing and plate facing in the directions shown on the right.



#### CAUTION

It will not be possible to attach the spring cover if the direction is incorrect, resulting in possible robot malfunction.

#### Step 1 Plastic bearing attachment

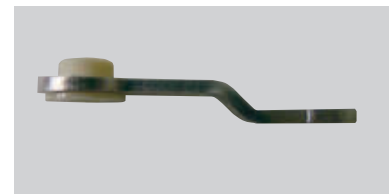



## 2. Plastic bearing inspection

Measure the width of the gap between the two shaft joints with calipers and so on.

This measurement includes the width of two plastic bearings, and therefore the amount of wear for one plastic bearing will be half of the measured value.

(Example) If the initial measurement value is 149.50mm and this value has reached 149.42mm when carrying out period measurement, the amount of wear per bearing will be 0.04mm.

Plastic bearing replacement guideline: when amount of wear reaches 0.5mm

When replacing plastic bearings, be sure to check and take a note of the measurement result, and periodically measure the amount of wear.

### Measurement method

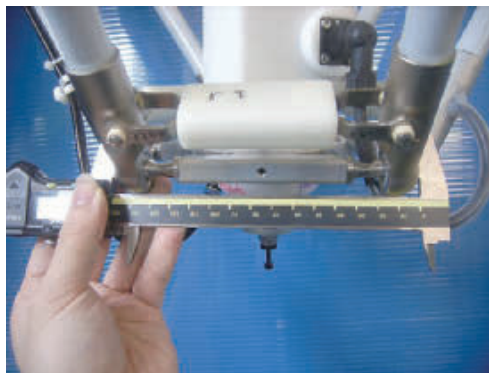

### Plastic bearing wear debris precautions

- Wear debris removal is necessary when cleaning in food-related industries.
- Wear debris removal in industrial applications should be carried out as required.



## Chapter 8

# $\theta$ -axis seal, O-ring replacement

### Contents

<b>1.</b>	<b><math>\theta</math>-axis seal, O-ring replacement procedure</b>	<b>8-1</b>
<b>1.1</b>	<b><math>\theta</math>-axis seal, O-ring removal</b>	<b>8-1</b>
<b>1.2</b>	<b><math>\theta</math>-axis seal, O-ring attachment</b>	<b>8-3</b>



# 1. $\theta$ -axis seal, O-ring replacement procedure

## 1. Replacement parts

	Part Name	OMRON Part No.	Part No. / Specs	Q'ty	Remarks
1	Seal (small)	KDL-M219K-00x		1	Inside $\theta$ -axis housing, small side
2	Seal (large)	KDL-M219K-10x		1	Inside $\theta$ -axis housing, large side
3	O-ring	KN5-M2144-00x		1	Housing side
4	O-ring	KN6-M1895-00x		1	$\theta$ -axis motor cover side
5	Housing	KDL-M1811-00x		1	
6	Housing securing bolt	91380-04020	M4, length 20	6	
7	Tool flange	KDL-M1843-00x		1	
		KDL-M1844-00x		1	
8	Tool flange securing bolt	91380-04012	M4, length 12	2	
9	Tool flange cover	KDL-M1816-00x		1	Rubber cover

- $\theta$ -axis seal recommended grease: CASSIDA grease EPS2

## 1.1 $\theta$ -axis seal, O-ring removal

The procedure described below is for the R6Y31110L03067NJ5 and R6Y31110H03067NJ5 (4-axes specification).

- Remove the  $\theta$ -axis motor cover.**  
When removing the  $\theta$ -axis motor cover, first disconnect the  $\theta$ -axis cable and then remove the moveable base from the shafts before proceeding.

Refer to "1.2 Detaching or attaching the  $\theta$ -axis cover" in Chapter 2 for details.
- Remove the O-ring from the groove in the moveable base at the motor cover side.**

### Step 2 O-ring removal



- 3 **Remove the tool flange.**  
Remove the rubber cover, remove the M4 hex socket head bolts, and then remove the tool flange.
- 4 **Remove the six length 20 M4 hex socket head bolts from the moveable base.**  
These bolts secure the moveable base and housing.
- 5 **Remove the housing from the moveable base.**  
The housing will still be attached to the moveable base a little.

▶ Step 3 **Tool flange removal**



▶ Step 4 **M4 hex socket head bolt removal**

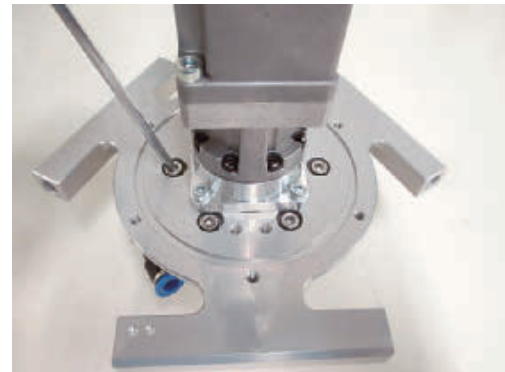

▶ Step 5 **Housing removal**



6 **Remove the O-ring from the groove on the moveable base at the housing side.**

▶ Step 6 **O-ring removal**



7 **Remove the two seals from the housing.**

The seals can be easily removed by prizing them free with a precision flat screw driver as shown on the right.

▶ Step 7 **Seal removal**

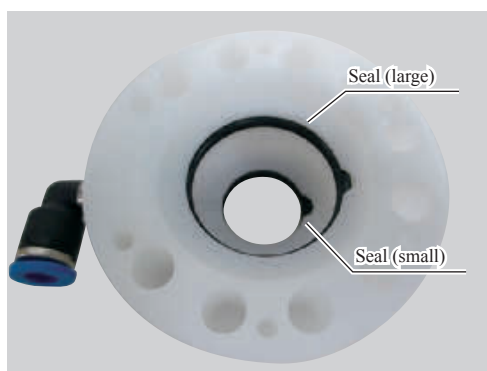

## 1.2 θ-axis seal, O-ring attachment

Fit the seals using the opposite of the procedure used for removal.

1 **Fit the two seals to the housing.**  
If unable to attach the seals properly as shown on the right, attach by pressing in a little, and ensure that the seals are not twisted.

▶ Step 1 **Seal attachment**



2 **Apply a thin layer of grease to the sliding areas between the seal and θ-axis shaft, and moveable base.**  
Apply a layer of grease so that the seal groove appears slightly white.

- Recommended grease: CASSIDA grease EPS2

▶ Step 2 **Grease application**

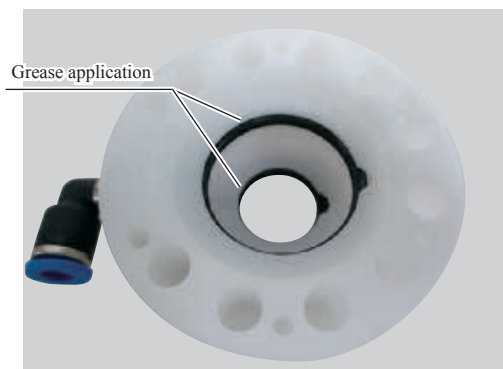

- 3 *Apply a thin layer of the recommended grease to the θ-axis shaft and sliding part of the housing.*
  - Recommended grease: CASSIDA grease EPS2
- 4 *Attach the O-ring to the groove in the moveable base at the housing side.*

▶ Step 3 Grease application

---



▶ Step 4 O-ring attachment

---





5

**Attach the housing.**

Push the housing until it is aligned with the underside of the moveable base so that the air tube attachment port is on the  $\beta$ -axis side.

After pushing in, tighten the six length 20 M4 hex socket head bolts.

- Tightening torque: 2Nm



**CAUTION**

Attach the housing with the housing side O-ring attached to the moveable base part. Furthermore, ensure that the housing is aligned with the underside of the moveable base.

Pickup will not be possible if the O-ring has not been attached, or the housing has not been attached sufficiently.

▶ **Step 5**

**Housing attachment**

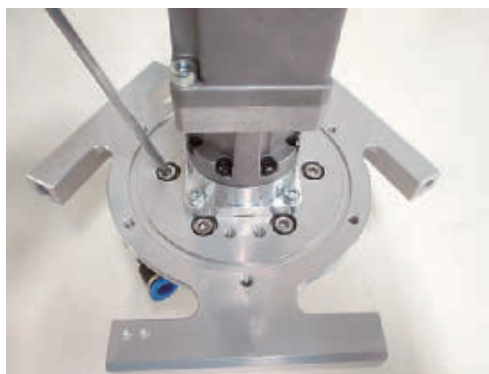
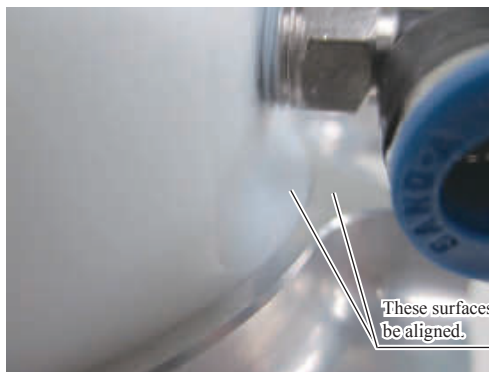

6

**Install the tool flange.**

Remove grease from the  $\theta$ -axis shaft (tool flange attachment part).

The tool flange is shaped so that it fits into the  $\theta$ -axis shaft groove.

7

**Attach the tool flange with the two M4 hex socket head bolts.**

- Tightening torque: 4.5Nm

**CAUTION**

Tighten the two M4 hex socket head bolts evenly.

Slippage may occur between the  $\theta$ -axis shaft and seal flange if one bolt is tightened more than the other.

▶ Step 6-7 **Tool flange installation**

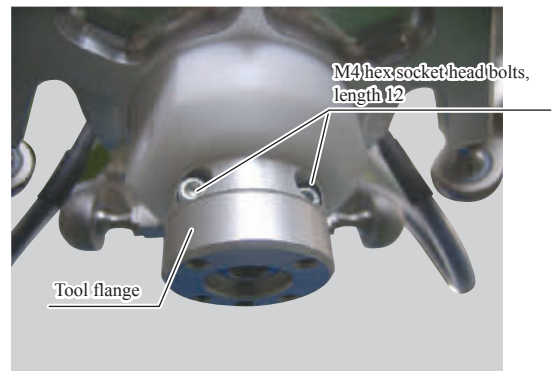
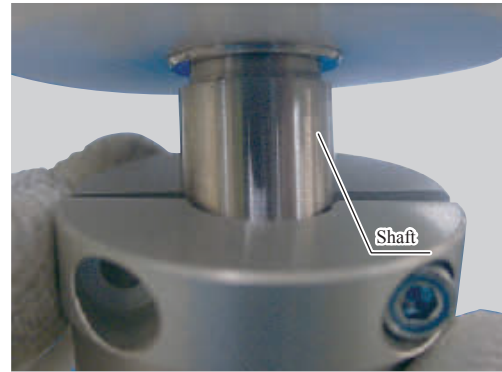
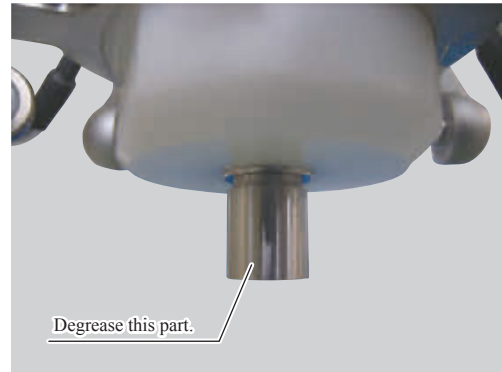

8 *Attach the rubber cover to the tool flange.*

9 *Attach the O-ring to the groove in the moveable base at the motor side.*

10 *Attach the  $\theta$ -axis motor cover.*

Refer to "1.2 Detaching or attaching the  $\theta$ -axis cover" in Chapter 2 for details.

▶ Step 8 **Rubber cover attachment**



▶ Step 9 **O-ring attachment**





# Chapter 9 Motor replacement

## Contents

<b>1. <math>\alpha</math>, <math>\beta</math>, <math>\gamma</math>-axis motor replacement</b>	<b>9-1</b>
<b>1.1 <math>\alpha</math>, <math>\beta</math>, <math>\gamma</math>-axis motor replacement procedure</b>	<b>9-1</b>
1.1.1 $\alpha$ , $\beta$ , $\gamma$ -axis motor removal	9-1
1.1.2 $\alpha$ , $\beta$ , $\gamma$ -axis motor attachment	9-3
<b>2. <math>\theta</math>-axis motor replacement</b>	<b>9-4</b>
<b>2.1 <math>\theta</math>-axis motor removal</b>	<b>9-4</b>



# 1. $\alpha$ , $\beta$ , $\gamma$ -axis motor replacement



## WARNING

IF REPLACING A MOTOR WITH SHAFTS, MOVEABLE BASE, AND ARM ATTACHED, PLACE A SUPPORT UNDER THE MOVEABLE BASE TO PREVENT IT FALLING. AND IF REPLACING A MOTOR WITH ONLY THE ARM ATTACHED, PLACE A SUPPORT UNDER THE ARM OR STRAP IT UP WITH SOME STRING TO PREVENT IT FALLING.

## 1. Replacement parts

	Part Name	OMRON Part No.	Part No. / Specs	Q'ty <sup>*1</sup>	Remarks
1	Motor	R88M-K1K030T-BS2 <sup>*2</sup>	1000W, 200 V, with brake	1	For $\alpha$ , $\beta$ and $\gamma$ -axes
2	Motor securing bolt	91312-08020	M8, length 20	4	
3	O-ring	90200-03J850		1	Attached to speed reduction gear groove.

\*1 : Quantity per axis

\*2 : For installation, remove the key

## 1.1 $\alpha$ , $\beta$ , $\gamma$ -axis motor replacement procedure

### 1.1.1 $\alpha$ , $\beta$ , $\gamma$ -axis motor removal



## NOTE

The same procedure is used to replace the  $\alpha$ ,  $\beta$  and  $\gamma$ -axis motors.

- 1 Post a sign indicating that the robot is being adjusted.**  
Post a sign indicating that the robot is being adjusted to prevent others from turning on the controller power.
- 2 Enter the safety enclosure.**
- 3 Remove the motor cover.**  
Refer to "1. Detaching, attaching, and replacing the covers" in Chapter 2 for details.
- 4 Remove the speed reduction gear cap bolt.**  
If the set screw is not visible inside the hole when the cap bolt is removed, release the motor brake, move the arm to a position at which the set screw becomes visible, and then adjust (if the arm has been removed, rotate the speed reduction gear to adjust the position.)



## CAUTION

If removing the motor with the arm still attached, it will fall suddenly when the motor brake is released, and must therefore be supported. And if removing the motor with the shafts and moveable base still attached, the moveable base must be supported to prevent it dropping suddenly.

### ▶ Step 4 Cap bolt removal

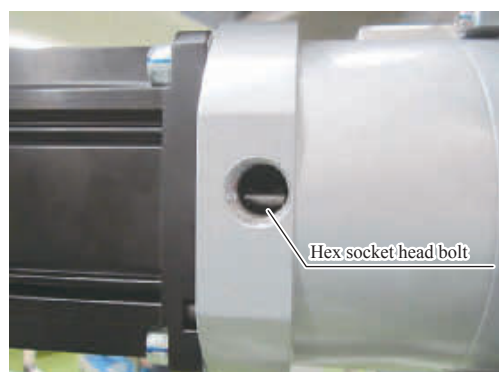
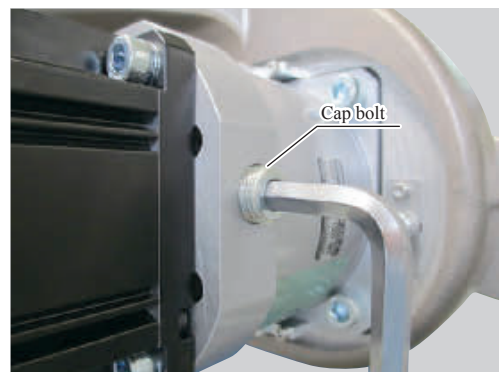

5 *Loosen the M6 hex socket head bolt connecting the speed reduction gear and motor shaft.*

6 *Remove the four M8 hex socket head bolts securing the motor to the speed reduction gear.*

When attaching, tighten with a torque of 37Nm.



**CAUTION**

Take care to prevent the motor falling when the bolts are removed.

7 *Pull the motor from the speed reduction gear to remove.*



**CAUTION**

The motor is relatively heavy and should therefore be supported with both hands when removing.

8 *Attach the O-ring to the groove in the speed reduction gear (when replacing the O-ring).*

▶ Step 5 **Loosen the M6 hex socket head bolt.**



▶ Step 6 **Hex socket head bolt removal**

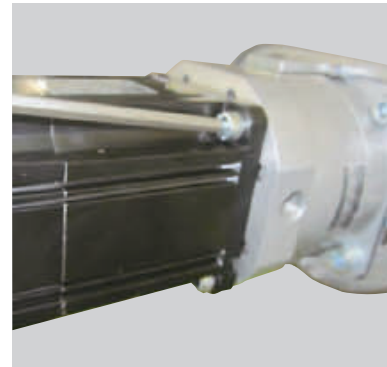

▶ Step 7 **Motor removal**

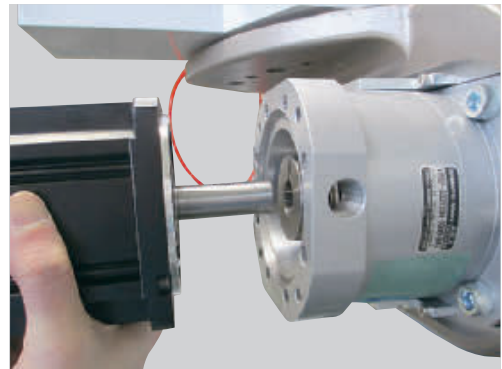

▶ Step 8 **O-ring removal**

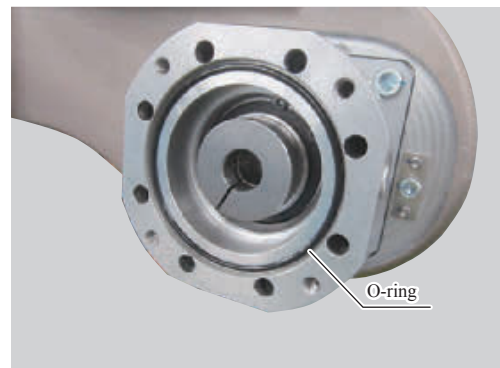



## 1.1.2 $\alpha$ , $\beta$ , $\gamma$ -axis motor attachment

Attach the motors using the opposite of the procedure used for removal.  
When doing so, the following additional procedures are necessary.

- Use a waste cloth to remove any grease from the motor shaft and speed reduction gear attachment surfaces.
- To make it easier to secure the motor shaft to the speed reduction gear, rotate the speed reduction gear beforehand so that the gear hex socket head bolt is visible from the cap attachment hole.
- When attaching the motor, fit an O-ring to the speed reduction gear.
- Attach the motor with the connector facing to the inside.

### O-ring attachment



### Motor attachment direction

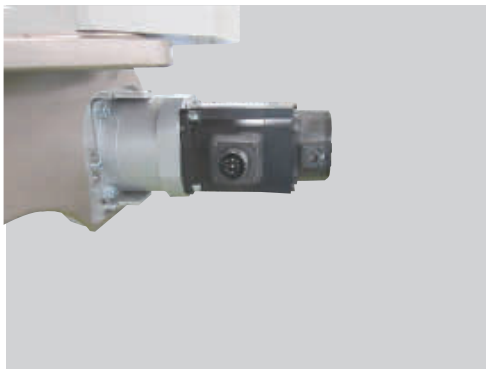

## 2. $\theta$ -axis motor replacement

### 1. Replacement parts

	Part Name	OMRON Part No.	Part No. / Specs	Q'ty	Remarks
1	Motor	R88M-K05030T-S2 <sup>*1</sup>	50W, 200 V, without brake	1	For R6Y31110L03067NJ5
		R88M-K10030T-S2 <sup>*1</sup>	100W, 200V, without brake	1	For R6Y31110H03067NJ5
2	Motor securing bolt	91380-04014	M4, length 14	2	Common to R6Y31110L03067NJ5, R6Y31110H03067NJ5

\*1 : For installation, remove the key

### 2.1 $\theta$ -axis motor removal

The procedure required to replace the  $\theta$ -axis motor only is described below. Refer to "2.3  $\theta$ -axis speed reduction gear replacement" in Chapter 10 if removing the speed reduction gear also.

- 1 Remove the moveable base from the shaft.**  
Refer to the "1. Shaft, moveable base, and spring cover replacement procedure" in Chapter 5 for details.
- 2 Remove the  $\theta$ -axis motor cover.**  
Refer to the "1. Shaft, moveable base, and spring cover replacement procedure" in Chapter 5 for details.
- 3 Remove the two M4 hex socket head bolts securing the motor to the speed reduction gear.**
- 4 Loosen the two speed reduction gear set screws.**  
Remove the gasket and then loosen the set screws.
- 5 Remove the motor from the speed reduction gear.**

Attach the motor using the opposite of the procedure used for removal.

Refer to "2.3  $\theta$ -axis speed reduction gear replacement" in Chapter 10 for details.

#### Step 3 M4 hex socket head bolt removal



#### Step 4 Set screw area

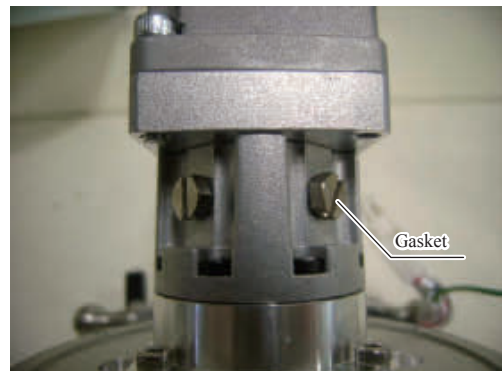

## Chapter 10

# Speed reduction gear, arm replacement

## Contents

<b>1. Speed reduction gear replacement precautions</b>	<b>10-1</b>
<b>2. Speed reduction gear and arm replacement procedure</b>	<b>10-2</b>
<b>2.1 <math>\alpha</math>, <math>\beta</math>, <math>\gamma</math>-axis arm replacement</b>	<b>10-2</b>
2.1.1 Work required after replacing arm link balls	10-3
<b>2.2 <math>\alpha</math>, <math>\beta</math>, <math>\gamma</math>-axis speed reduction gear replacement</b>	<b>10-4</b>
<b>2.3 <math>\theta</math>-axis speed reduction gear replacement</b>	<b>10-7</b>



# 1. Speed reduction gear replacement precautions

Speed reduction gear replacement precautions are described below. Always read the following replacement procedures and precautions before carrying out replacement work.

## ■ Speed reduction gear replacement precautions



### WARNING

- THE MOTOR AND SPEED REDUCTION GEAR CASING WILL BECOME VERY HOT SHORTLY AFTER OPERATION, RESULTING IN BURNS IF TOUCHED. BEFORE TOUCHING THESE PARTS, TURN OFF THE CONTROLLER, WAIT FOR A WHILE, AND THEN CHECK THAT THE TEMPERATURE HAS SUFFICIENTLY COOLED.

### DEGREASING AND WASHING PRECAUTIONS

- THE EYES MAY BECOME INFLAMED IF EXPOSED TO GREASE OR DETERGENT ON THE WASTE CLOTH USED FOR GREASE REMOVAL. BEFORE HANDLING THE GREASE, WEAR YOUR SAFETY GOGGLES TO ENSURE THE GREASE WILL NOT COME IN CONTACT WITH THE EYES.
- INFLAMMATION MAY OCCUR IF THE GREASE COMES INTO CONTACT WITH SKIN. BE SURE TO WEAR PROTECTIVE GLOVES TO PREVENT CONTACT WITH SKIN.
- DO NOT TAKE ORALLY OR EAT. (EATING WILL CAUSE DIARRHEA AND VOMITING.)
- KEEP OUT OF THE REACH OF CHILDREN.

### EMERGENCY TREATMENT:

- IF GREASE OR DETERGENT SPLATTERS AND GETS INTO THE EYES, RINSE WITH CLEAN WATER FOR 15 MINUTES AND THEN CONSULT A PHYSICIAN.
- IF THIS GREASE COMES IN CONTACT WITH THE SKIN, WASH AWAY COMPLETELY WITH SOAP AND WATER.
- IF TAKEN INTERNALLY, DO NOT INDUCE VOMITING BUT PROMPTLY CONSULT A PHYSICIAN FOR TREATMENT.



### CAUTION

About the speed reduction gear

- Do not apply strong force to any of the parts with a hammer and so on. Furthermore, be careful not to drop any of the parts, as this may result in scratches or dents, leading to likely speed reduction gear damage.
- If the speed reduction gear is used in a damaged condition, it will not function at its specified performance. Furthermore, using in this condition may lead to problems such as complete gear break-down.
- The speed reduction gear will shift when replaced, and therefore it is necessary to adjust the origin position following replacement.

## 2. Speed reduction gear and arm replacement procedure

The replacement procedure and precautions for speed reduction gears and arms are listed below.

Refer to the following table for bolt tightening torque values required when replacing speed reduction gears or arms. However, please follow the instructions given at each replacement procedure for the tightening torque applied to bolts used to secure reduction gears and arms. OMRON bolts should be used.

### ■ Bolt tightening torque

Bolt size	Tightening torque (kgfcm)	Tightening torque (Nm)
M3 set screw	20	2
M3	20	2
M4	46	4.5
M4 4-axes specification $\alpha$ -axis arm cable clamp	20	2
M6	156	15.3
M8	380	37
M10	540	53
M12	1310	128

Recommended "Screw Lock": LOCTITE 241 (made by Henkel Corporation)

### 2.1 $\alpha$ , $\beta$ , $\gamma$ -axis arm replacement



#### WARNING

CARRY OUT REPLACEMENT AFTER READING "1. DETACHING, ATTACHING, AND REPLACING THE COVERS" IN CHAPTER 2.



#### NOTE

The arm replacement procedure is the same for the  $\alpha$ ,  $\beta$  and  $\gamma$ -axes.

The requirements for  $\alpha$ ,  $\beta$  and  $\gamma$ -axis arm replacement are as follows.

#### 1. Replacement parts

	Part Name	OMRON Part No.	Part No. / Specs	Q'ty <sup>*1</sup>	Remarks
1	Arm	KDL-M1520-00x		1	
2	Arm securing bolt	91312-08020	M8, length 20	6	
3	Cap	KDL-M1561-00x		1	Arm attachment part
4	link ball	KDL-M152A-00x		2	
5	Cap	KDL-M1562-10x		3	Cable attachment part Bolt hole filler plug (*2)
6	Clamp	KDL-M1573-00x		3	Plastic block (*3)
		KDL-M1574-00x		3	Plastic block (*3)
7	Pin	99480-03008		3	(*3)
8	Clamp securing bracket	91312-04010	M4, length 10	3	(*3)

\*1 : Quantity per axis

\*2 : With the R6Y30110S03067NJ5 (3-axes specification), this is necessary for the arms of each axis. With the R6Y31110L03067NJ5 and R6Y31110H03067NJ5 (4-axes specification), it is necessary for the  $\beta$  and  $\gamma$ -axis arms.

\*3 : These are only for the R6Y31110L03067NJ5 and R6Y31110H03067NJ5 (4-axes specification), and are used when securing the  $\theta$ -axis cable to the  $\alpha$ -axis arm.

## 2. Required tools

Name	Part No.	Manufacturer	Remarks
Cleaning wipe			
Hex wrench set			

The arm removal procedure is described below. Use the opposite procedure to perform arm attachment.

- 1 ***Post a sign indicating that the robot is being adjusted.***  
Post a sign indicating that the robot is being adjusted to prevent others from turning on the controller power.
- 2 ***Enter the safety enclosure.***
- 3 ***Remove the cap (white) from each axis arm.***  
The hex socket head bolt attachment surface is exposed by removing the cap.
- 4 ***Adjust the arm position (if replacing the speed reduction gear).***
- 5 ***Remove the length 20 M8 hex socket head bolt used to secure the arm for each axis to its respective speed reduction gear.***  
Tighten the bolts with a tightening torque of 37Nm when attaching the arm.
- 6 ***Remove each axis arm.***

### ▶ Step 3 When cap removed from arm



### 2.1.1 Work required after replacing arm link balls

The link ball attachment method is described here.

- 1 ***Apply a thin layer of Loctite screw lock to the link ball screw.***  
Use Henkel Loctite 241 (blue).
- 2 ***Attach a link ball to two locations on each axis arm.***  
Attach to a total of six locations on the  $\alpha$ ,  $\beta$  and  $\gamma$ -axes.

### ▶ Step 2 Link ball attachment



- 3 **Tighten the link balls with a tool.**  
 • Tightening torque: 20Nm

▶ **Step 3** **Tightening with tool**



## 2.2 $\alpha$ , $\beta$ , $\gamma$ -axis speed reduction gear replacement



**NOTE**  
 The same procedure is used to replace the  $\alpha$ ,  $\beta$  and  $\gamma$ -axis speed reduction gears.

The requirements for  $\alpha$ ,  $\beta$  and  $\gamma$ -axis speed reduction gear replacement are as follows.

### 1. Replacement parts

	Part Name	OMRON Part No.	Part No. / Specs	Q'ty*	Remarks
1	Speed reduction gear	KDL-M211A-00x		1	For $\alpha$ , $\beta$ and $\gamma$ -axes
2	Speed reduction gear mounting bolt	90112-10J030	M10, length 30	4	

\*1 : Quantity per axis

### 2. Required tools

Name	Part No.	Manufacturer	Remarks
Cleaning wipe			
Hex wrench set			
Screw thread locking agent	Loctite 241	Henkel	Medium-strength type (blue)

### ■ Removal

- 1 **Post a sign indicating that the robot is being adjusted.**  
 Post a sign indicating that the robot is being adjusted to prevent others from turning on the controller power.

- 2 **Enter the safety enclosure.**



**CAUTION**  
 The robot body is extremely heavy, and therefore care should be taken when carrying out replacement work.

- 3 **Remove the relevant axis motor.**  
 Refer to "1.1  $\alpha$ ,  $\beta$ ,  $\gamma$ -axis motor replacement procedure" in Chapter 9 for details on motor replacement.



#### 4 **Loosen the bracket hex socket head bolts.**

Loosen the length 20 M4 hex socket head bolts on the bracket used to secure the motor cover attached above and below the speed reduction gear. The speed reduction gear can be easily removed by loosening the bracket. Remove the bracket if still difficult to remove the speed reduction gear even after loosening.

#### 5 **Remove the M10 hex socket head bolts used to secure the speed reduction gear to the base.**

Tighten the bolts with a tightening torque of 53Nm when reattaching.

#### 6 **Remove the speed reduction gear.**

Keep the angle of the speed reduction gear steady and remove slowly while supporting with both hands. If the angle is not kept steady and the speed reduction gear becomes stuck on the base, it will be difficult to remove.

If the brackets used to secure the motor cover attached above and below the speed reduction gear become caught, remove them.



#### CAUTION

Do not apply excessive force to remove the speed reduction gear. Doing so may result in gear malfunction.

#### ▶ Step 4 **Loosen the M4 hex socket head bolts.**

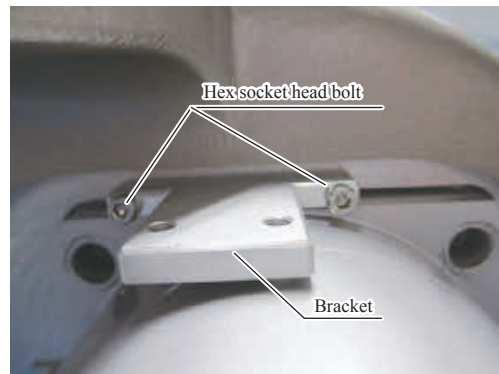

#### ▶ Step 5 **Speed reduction gear hex socket head bolt removal**

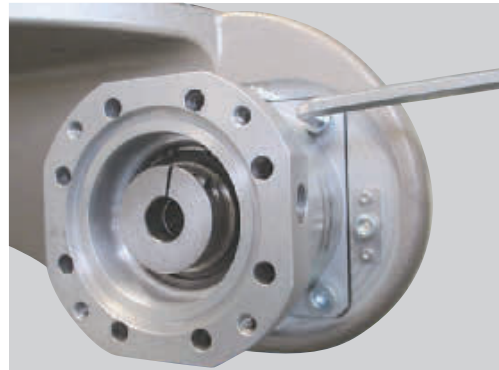

#### ▶ Step 6 **Speed reduction gear removal**

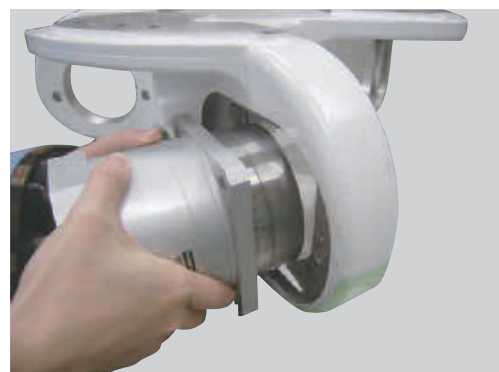

## ■ Attachment

Attach the speed reduction gear using the opposite of the procedure used for removal.  
Attach the speed reduction gear so that the cap bolts are on the outside.



### CAUTION

- The speed reduction gear is extremely heavy and should therefore be supported with both hands when attaching.
- Insert the speed reduction gear slowly while holding it perpendicular to the base at the same angle. It will be difficult to insert the reduction gear into the base if at angle.
- Try again if unable to insert the speed reduction gear properly. Using excessive force to insert the gear may damage it.

### Speed reduction gear attachment condition

Arm side

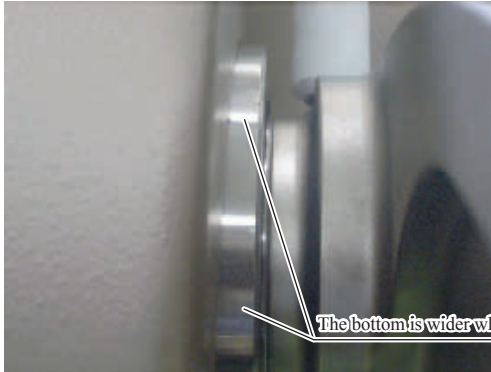

Motor side



## 2.3 $\theta$ -axis speed reduction gear replacement

The requirements for  $\theta$ -axis speed reduction gear replacement are as follows.

### 1. Replacement parts

	Part Name	OMRON Part No.	Part No. / Specs	Q'ty*	Remarks
1	Speed reduction gear	KDL-M1822-00x		1	For R6Y31110L03067NJ5
		KDL-M1822-10x		1	For R6Y31110H03067NJ5
2	Speed reduction gear mounting bolt	91380-03010	M3, length 10	4	Common to R6Y31110L03067NJ5, R6Y31110H03067NJ5
3	$\theta$ -axis shaft	KDL-M1870-00x		1	
4	Shaft securing bolt	91380-03008	M3, length 8	3	
5	Spacer	KDL-M1830-00x		1	
6	Spacer securing bolt	91380-04008	M4, length 8	6	

### 2. Required tools

Name	Part No.	Manufacturer	Remarks
Cleaning wipe			
Hex wrench set			
Screw thread locking agent	Loctite 241	Henkel	Medium-strength type (blue)

### ■ Removal

- 1 ***Post a sign indicating that the robot is being adjusted.***  
Post a sign indicating that the robot is being adjusted to prevent others from turning on the controller power.
- 2 ***Enter the safety enclosure.***
- 3 ***Remove the end effector.***  
Refer to "6. Attaching the end effector" in Chapter 2 of the installation manual for details.
- 4 ***Disconnect the air tube from the joint on the user tubing.***



#### CAUTION

Do not carry out replacement work with the air tube still attached to the joint on the user tubing. By doing so, the air tube may bend.

- 5 ***Disconnect the cable from the  $\theta$ -axis motor cover.***

Refer to "1. Shaft, moveable base, and spring cover replacement procedure" in Chapter 5 for details.



#### CAUTION

Do not carry out replacement work with the cable still attached to the  $\theta$ -axis motor. By doing so, the cable may be damaged.

**6** *Remove the moveable base from the shafts.*

Refer to "1. Shaft, moveable base, and spring cover replacement procedure" in Chapter 5 for details.

**7** *Remove the  $\theta$ -axis motor cover.*

Refer to "1. Detaching, attaching, and replacing the covers" in Chapter 2 for details.

**8** *Remove the motor cover side O-ring.*

**9** *Remove the tool flange.*

Refer to "1.1  $\theta$ -axis seal, O-ring removal" in Chapter 8 for details.

**10** *Remove the housing.*

**11** *Remove the O-ring at the housing side.*

**12** *Remove the shaft attached to the speed reduction gear.*

Insert a hex wrench through the shaft through hole to prevent the axis rotating, and then remove the six M3 hex socket head bolts.

**13** *Remove the spacer.*

Use a spanner to prevent the axis rotating, and then remove the three M4 hex socket head bolts.

**14** *Pull the motor and speed reduction gear assembly from the moveable base.*

Remove the four M3 hex socket head bolts from the speed reduction gear brackets.

**15** *Remove the two M4 hex socket head bolts securing the motor to the speed reduction gear.*

**16** *Loosen the two speed reduction gear set screws.*

**17** *Remove the motor from the speed reduction gear.*

▶ **Step 12** **Shaft removal**



▶ **Step 13** **Spacer removal**



▶ **Step 15** **M4 hex socket head bolt removal**



▶ **Step 17** **Speed reduction gear removal**



## ■ Attachment

Attach the speed reduction gear using the opposite of the procedure used for removal.

- 1 **Attach the motor to the speed reduction gear.**
- 2 **Tighten the two speed reduction gear set screw.**
  - Tightening torque: 69Nm
- 3 **Attach the two length 14 M4 hex socket head bolts used to secure the motor to the speed reduction gear.**
  - Tightening torque: 4.5Nm
- 4 **Insert the motor and speed reduction gear assembly into the moveable base.**

Ensure that the motor connector side is facing the moveable base  $\alpha$ -axis side.



### WARNING

IF THE ATTACHMENT DIRECTION IS INCORRECT, IT WILL NOT BE POSSIBLE TO PROPERLY EARTH THE  $\theta$ -AXIS MOTOR COVER WHEN ATTACHED, RESULTING IN POSSIBLE ELECTRIC SHOCK.

### ▶ Step 1 Speed reduction gear attachment



### ▶ Step 3 Bolt attachment



### ▶ Step 4 Assembly attachment



5 *Temporarily tighten the speed reduction gear to the moveable base with the four length 10 M3 hex socket head bolts.*

6 *Center the rotational axis.*

Align the rotation centering jig with the center of the speed reduction gear axis.

Secure to the moveable base at two of the six bolt locations with the M4 bolts, adjust to center the  $\theta$ -axis, and then fully tighten the bolts temporarily tightened at Step 5.

- Tightening torque: 2Nm

After tightening, remove the two M4 bolts used to secure the moveable base, and then remove the rotation centering jig.

▶ Step 5

Temporary tightening



▶ Step 6

Rotation centering jig attachment

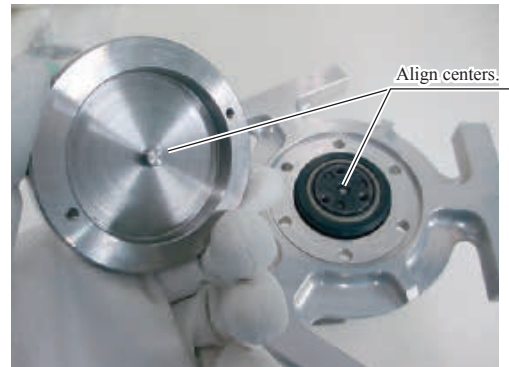



7

***Attach the spacer.***

Use a spanner to prevent the axis rotating, and then attach the three length 8 M4 hex socket head bolts.

- Tightening torque: 4.5Nm

8

***Attach the shaft.***

Insert a hex wrench through the shaft through hole to prevent the axis rotating, and then attach the six length 8 M3 hex socket head bolts.

- Tightening torque: 2Nm

9

***Apply a thin layer of the recommended grease to the shaft and sliding part of the housing.***

- Recommended grease: CASSIDA grease EPS2

10

***Attach the O-ring at the housing side.***

Refer to “1.2  $\theta$ -axis seal, O-ring attachment” in Chapter 8 for details.

11

***Attach the housing.***

Refer to “1.2  $\theta$ -axis seal, O-ring attachment” in Chapter 8 for details.

## ▶ Step 7

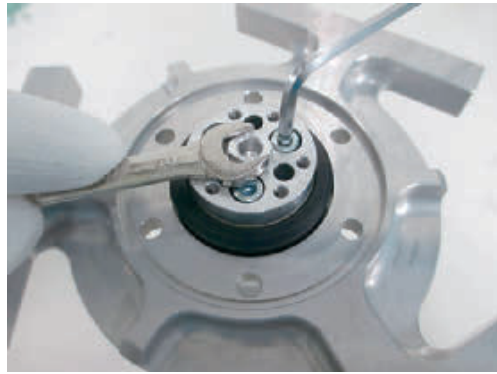
**Spacer attachment**

## ▶ Step 8

**Shaft attachment**

## ▶ Step 9

**Grease application**





# Chapter 11 Maintenance parts

## Contents

- |                        |      |
|------------------------|------|
| 1. Consumable parts    | 11-1 |
| 2. Basic specification | 11-2 |



# 1. Consumable parts

Consumable part	Q'ty	Remarks
KDL-M152K-00x	24	Plastic bearing 1
KDL-M152J-00x	12	Plastic bearing 2 (Replace if wear 0.5mm or greater.)
KDL-M219K-00x	1	Seal (inside $\theta$ -axis housing, small side)
KDL-M219K-10x	1	Seal (inside $\theta$ -axis housing, large side)
KDL-M150E-00x	1	Shaft ( $\alpha$ -axis motor cable side, 4-axes specification)
KDL-M150F-00x	1	Shaft ( $\alpha$ -axis encoder cable side, 4-axes specification)
KDL-M211A-00x	3	Speed reduction gear ( $\alpha$ , $\beta$ and $\gamma$ -axes)
KDL-M1822-00x	1	Speed reduction gear ( $\theta$ -axis)
KDL-M1822-10x	1	Speed reduction gear ( $\theta$ -axis)

- $\theta$ -axis seal recommended grease  
CASSIDA grease EPS2

## 2. Basic specification

Robot model		R6Y30110S03067NJ5	R6Y31110L03067NJ5	R6Y31110H03067NJ5
Working volume	X, Y axis	Stroke	Ø1100mm	
	Z axis	Stroke	300mm (max. Ø1100mm)/450mm (center Ø580mm)	
	θ axis	Rotation range		±180° (default setting, it can be changed)
Servo motor	Arm 1, 2, 3		1000W	
	Rotational axis 4		50W	100W
Repeatability <sup>*1</sup>	X, Y, Z axis		±0.2mm	
	θ axis			±0.1°
Maximum payload			3kg	
Maximum through-put <sup>*2</sup>			150 CPM <sup>*4</sup>	
θ axis tolerable moment of inertia <sup>*3</sup>			0.01kgm <sup>2</sup> (50W)	0.035kgm <sup>2</sup> (100W)
User tubing (outer diameter)			Ø6×1 (moveable tool)	
Travel limit			Soft limit	
Protection class			IP67	
Weight			75kg	

\*1: This is the value at a constant ambient temperature.

\*2: With 0.1kg payload. When reciprocating 305mm in horizontal and 25mm in vertical directions.

\*3: There are limits to acceleration coefficient settings.

\*4: CPM: Cycle per minutes. Check the note 2 for the cycle definition.

## Revision history

A manual revision code appears as a suffix to the catalog number on the front cover manual.

Cat. No. I195E-EN-01

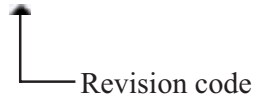

The following table outlines the changes made to the manual during each revision.

Revision code	Date	Description
01	June 2013	Original production

# OMRON

**Authorized Distributor:**